

HEAVY DUTY ALL-METAL EXPANSION JOINT SOLUTIONS FOR LARGE TRAFFIC LOADS

HARD WEARING, MAINTENANCE-FREE AND LONG LASTING



MIGUTRANS

YOU FIRST.

MIGUA is one of Europe's leading experts in the design, manufacture and installation of expansion joint systems. MIGUA expansion joint systems serve to cover, close and seal expansion joints. Our products satisfy the most rigorous standards in quality and safety and are widely used in large-scale construction projects such as airports, train stations, industrial plants, parking structures, shopping centres and hospitals. Every day, our experienced team do their utmost to ensure that our outstanding product quality and innovative approach make your building project successful. We are not satisfied until you are satisfied. Because our guiding principle is:

MIGUA – you first.

Over 600 products for one purpose:

Yours

With five brands and a total of over 600 proven expansion joint systems, we've got the diverse structural needs of today's construction projects covered. We confront problems such as heavy traffic loads and meet exacting standards in water resistance or hygiene. Floors, walls or roofs, MIGUA offers the perfect solution for any surface. Products of the highest quality are fundamental to our business; yet our ultimate priority is always customer satisfaction.



MIGUTEC

JOINT COVERS FOR
EXPANSION JOINTS

MIGUTRANS

HEAVY-DUTY ALL-METAL
JOINT SOLUTIONS
FOR LARGE TRAFFIC LOADS

MIGUTAN

WATERTIGHT EXPANSION
JOINT SOLUTIONS

MIGUPREN

EXPANSION JOINT STRIPS TO SEAL JOINTS
WITH THREE-DIMENSIONAL MOVEMENT

MIGUMAX

SEISMIC RESISTANT
EXPANSION JOINT SOLUTIONS

360°

MIGUA 360° SERVICE

TABLE OF CONTENTS

Introducing MIGUTRANS	4-5
Joints according to application areas/alphabetically sorted	6-7
Solid, full metal expansion joint constructions	
Expansion joints for high load requirements – FS	8-29
• With stainless steel or brass surfaces for high aesthetic demands	17
Expansion joints for retrofitted installation – FSN	30-34
Expansion joints for vibration-free driving – FS/FSS	35-36
Solid steel/stainless steel expansion joint constructions	
Expansion joints for maximum load requirements – STS	37-39
Watertight joints for maximum load requirements – STW	40-41
Technical appendix	
Expansion joints connections, intersections	42-43
Wall-connection versions, dimensions	44
Wall-connection versions E4	45-48
Wall-connection versions E3	49-51
Installation suggestions/Expansion joint cover combinations	52
Installation in screed/existing cut-outs	53
Installation in great construction heights/ extremely wide construction joints	54
With MIGUFOL tape	55
Corner solutions	56
Practical MIGUTRANS applications	57-58
Legal notes	59

WITH MIGUTRANS, MIGUA OFFERS A COMPREHENSIVE RANGE OF **SOLID FULL METAL EXPANSION JOINT COVERS FOR FLOORS WITH HIGH TRAFFIC LOADS.**

Today's modern architecture for shopping centres, stations, airports, trade centres or hospitals must meet a wide range of functions and accordingly withstand a variety of loads. The bandwidth extends from the light loads imposed by foot traffic, to cars and trucks, and through to the highest spot loads exerted by lifting trucks and forklifts. Expansion and building joints subject to traffic loads are particularly critical areas in the structure of buildings. Added to this are, depending on requirements, further criteria such as vibration-free driving for sensitive items, the ability to retrofit when renovating, or requirements with regard to special resistance to chemical attack and environmental influences through to water-proofing.

MIGUTRANS from MIGUA offers planners and architects a wide range of wear-resistant, maintenance free and long-lasting expansion joint constructions for demanding construction projects. A user-oriented, high-quality and internationally tried and tested range of expansion joints which meet the varying functional and aesthetic requirements of innovative architecture.

Test certificates

Official test certificates attesting to the payload are available and may be supplied on request.

Important notes

With low expansion joint heights, the low coverage requires epoxy resin strips with a bonding coat to be used.

In wet areas (industrial kitchens, sanitary rooms etc.) solid stainless steel expansion joint covers or our watertight MIGUTAN expansion joint constructions are to be used.

Special features

Absolutely equal height connection of the expansion joint cover lengths thanks to connecting pins or the insertion of brackets into one another.

Factory mounted spacers ensure joint covers set to mean point which in turn ensures economic installation and safe functional seating of the expansion joint construction.

On request, the expansion joint covers may be set at the factory thus ensuring one-sided maximisation of absorbed movement.

MIGUTRANS

HEAVY-DUTY ALL-METAL JOINT SOLUTIONS FOR LARGE TRAFFIC LOADS



Specifications regarding the load capacity

Pictogram					
Meaning	Pedestrians	Private cars	Lorries DIN 1072	Forklift trucks DIN 1055	Hard castors

The load specifications of air-filled and solid plastic tyre trucks apply to a wheel contact patch of 200 x 200 mm.

We reserve the right to make technical changes.

If you have any questions about our products, we would be happy to help.
+ 49 2058 774 0 or info@migua.de

Note regarding installation

Assembly and installation instructions are available on request. Please speak to us.

Alternatively, information can be downloaded from the Internet at www.migua.com.

When installing MIGUTRANS expansion joint constructions in mastic asphalt flooring, please request technical consultation.

EXPANSION JOINTS ACCORDING TO AREAS OF APPLICATION

SOLID, FULL METAL EXPANSION JOINT CONSTRUCTIONS

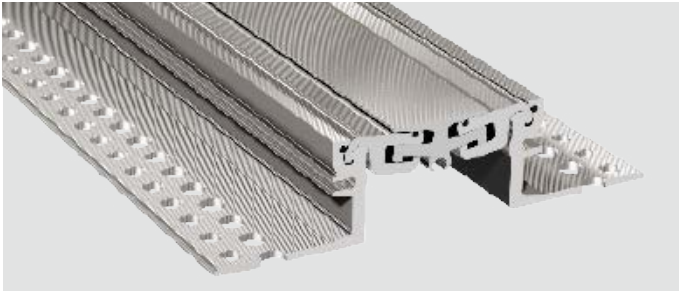

FS – Joints for high load requirements

For a variety of applications, the traffic loads to be planned e.g. imposed by cars, lie within a normal range. MIGUA offers three tried and tested product lines for this application. No compromises are made with regard to freedom from maintenance, wear-resistance and durability thanks to the robust construction which uses solid full aluminium and mature technical 3D joint constructions.

Higher traffic loads must be taken into consideration, in particular for public sector or industrial projects. MIGUA offers the most comprehensive range for this particular sector including a range of different planning parameters. The key criteria are pronounced movement abilities, wear-resistance and durability under load and are effectively met by these profile constructions thanks to the individually adapted joint technologies.

Product	Page
FS 40	8
FS 46	9
FS 50	10
FS 75	11
SFS 90 / 115 / 135	12
FS 99	13
FSL 104	14
FS 105	15
FS 110	16
FS 110 ES	17
FS 130	18
FS 135 / FS 174	19
FS 146	20
FS 155	21
FS 160	22
FS 185	23
FSV 235	24

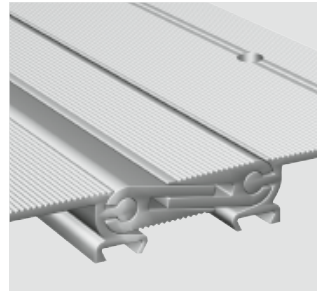

FSN – Joints for subsequent installation

MIGUA FSN joint constructions have upper brackets and are thus ideal for subsequent installation, particularly in renovation and modernisation projects. The highly developed joint constructions enable three-dimension movements to be absorbed and ensure maximum functionality even under difficult conditions. Structured surfaces and gap-free visual surfaces ensure high traffic safety.

Product	Page
FSN 50	30
FSN 99	31
FSN 146	32
FSN	33
FSN	34

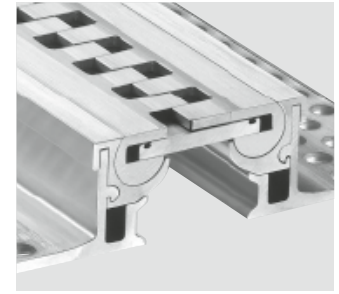

FS/FSS – Joints for vibration-free driving

Vibration-free driving is particularly relevant for the transportation of sensitive wares. The solid full aluminium expansion joint constructions FS/FSS meet this requirement in a particularly maintenance-free, wear-resistant and durable way. Fully moveable (FS 100) or with two-dimensional absorption of movement (FSS) they carry high traffic loads e.g. trucks or forklifts and are thus ideally suited to production and warehousing facilities.

Product	Page
FS 100	35
FSS 215	36

MASSIVE STAHL-/EDELSTAHL-FUGENKONSTRUKTIONEN

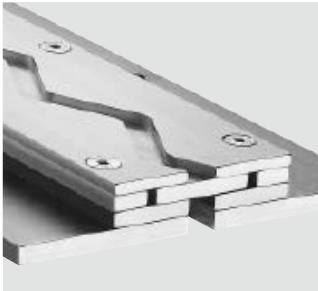

STS – Joints for maximum load requirements

With the STS line of products, MIGUA offers a range of aluminium/steel/stainless steel constructions for the highest of traffic loads imposed by forklifts, heavy-duty trucks or special vehicles. A particular criterion of this product line is the full vibration-free driving which effectively prevents damage to the building structure and vehicles. The extremely robust constructions also absorb horizontal movement reliably both across and parallel to the joint.

Product	Page
STS 100	37
STS 160	38
STS 160/16 / STS 160/22	39

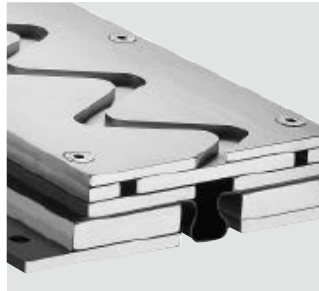

STW – Joints for maximum load requirements (watertight)

STW aluminium/steel/stainless steel constructions offer the same properties as STS – but with additional seal inserts. This enables the entire construction/joint construction to be made watertight (in conjunction with the appropriate connection joint). Vibration-free driving and reliable horizontal absorption of movement are also ensured with these joint covers: durably, maintenance-free and, just like the STS, with full dismantling and reversing options.

Product	Page
STW 100	40
STW 160	41

EXPANSION JOINTS IN ALPHABETICAL ORDER

Product	Page
FS 40	8
FS 46	9
FS 50	10
FS 75	11
FS 99	13
FS 100	35
FS 105	15
FS 110	16
FS 110 ES	17
FS 130	18
FS 135 / FS 174	19
FS 146	20
FS 155	21
FS 160	22
FS 185	23
FS 220 / FS 260 / FS 380	28
FS 255 / FS 295 / FS 410	29
FSL 104	14
FSN	33
FSN	34
FSN 50	30
FSN 99	31
FSN 146	32
FSS 215	36
FSV 235	24
FSV 280	25
FSV 285	26
FSV 335	27
SFS 90 / 115 / 135	12
STS 100	37
STS 160	38
STS 160/16 / STS 160/22	39
STW 100	40
STW 160	41

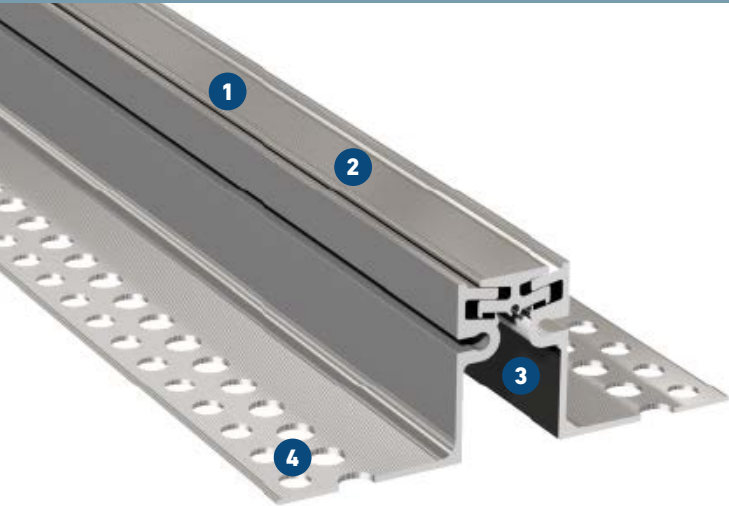

- 1** **Symmetrical visible surface**
- 2** **Striated surface**
ensures good skid resistance
- 3** **Solid all-metal expansion joint**
heard wearing, maintenance-free, long lasting
- 4** **MultiHole mounting bracket**
for secure fixing

Expansion joint cover	Joint width max. b_f [mm]	Total movement Δb_f [mm]	Visible width b_s [mm]	Joint width total b_t [mm]	Joint height h^a [mm]	Load bearing capacity [kN]	Load bearing capacity [kN]	Load bearing capacity solid plastic tyres [kg/mm]
FS 40/19	35	16 (± 8)	40	173	19	300	70	6,5
FS 40/25	35	16 (± 8)	40	161	25	300	70	6,5
FS 40/35	35	16 (± 8)	40	163	35	300	70	6,5
FS 40/60	35	16 (± 8)	40	163	60	300	70	6,5

Production length: 4 m

Standard colour: Aluminium

Larger installation heights on request.

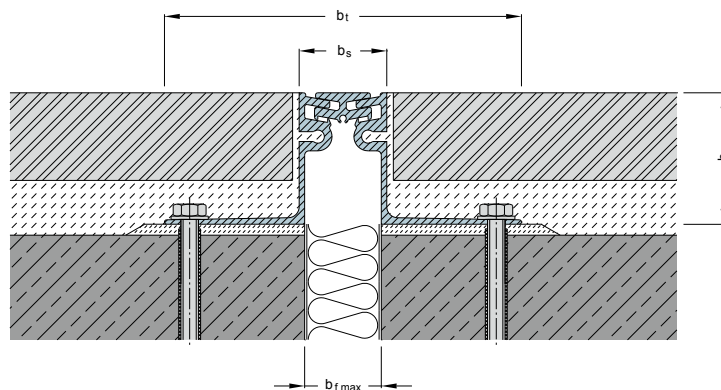

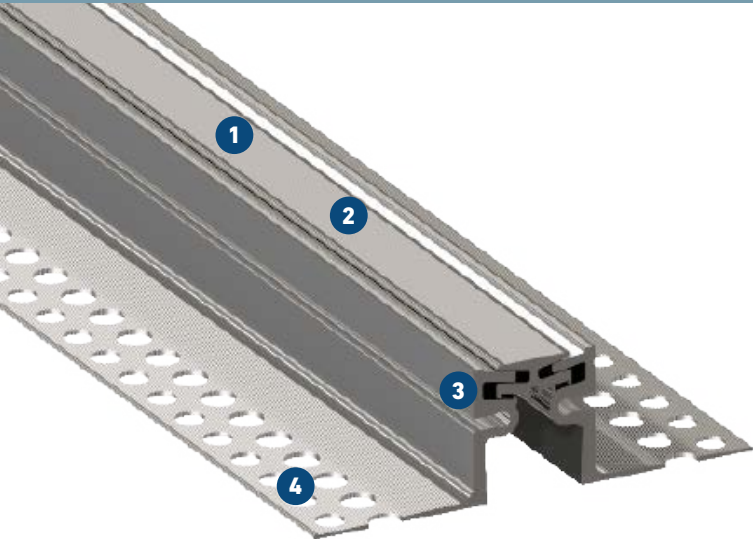

- 1** Symmetrical visible surface
- 2** Striated surface
ensures good skid resistance
- 3** Solid all-metal expansion joint
heard wearing, maintenance-free, long lasting
- 4** MultiHole mounting bracket
for secure fixing

Expansion joint cover	Joint width max. b_f [mm]	Total movement Δb_f [mm]	Visible width b_s [mm]	Joint width total b_t [mm]	Joint height h^a [mm]	Load bearing capacity [kN]	Load bearing capacity [kN]	Load bearing capacity solid plastic tyres [kg/mm]
FS 46/50	35	20 (± 10)	46	165	50	300	70	6,5

Production length: 4 m
Standard colour: Aluminium
 Larger installation heights on request.

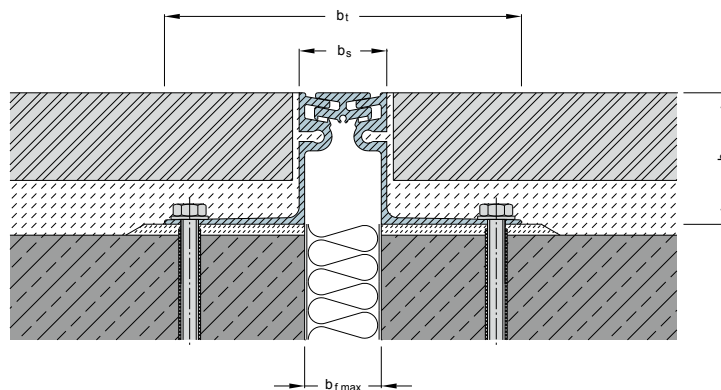

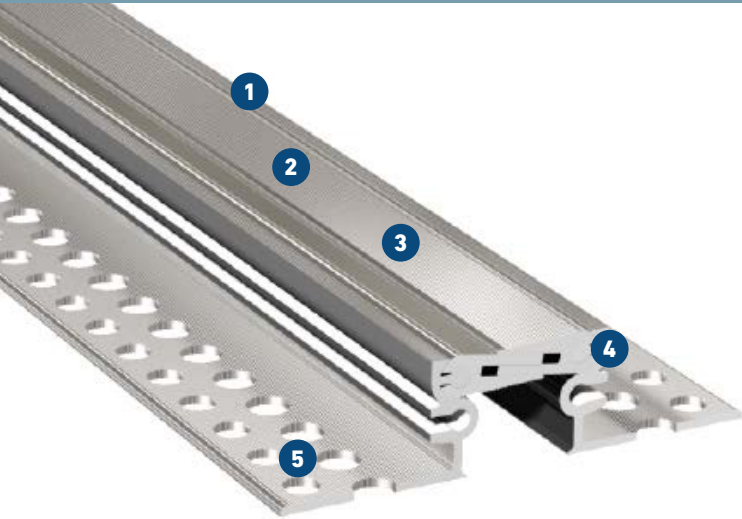

- 1 Solid all-metal expansion joint**
hard wearing, maintenance-free, long lasting
- 2 Striated surface**
ensures good skid resistance
- 3 Visible surface has no gaps**
avoids dirt accumulation
- 4 Articulated telescoping system**
absorbs movement in 3 directions
- 5 MultiHole mounting bracket**
for secure fixing

Expansion joint cover	Joint width max. b_f [mm]	Total movement Δb_f [mm]	Visible width b_s [mm]	Joint width total b_t [mm]	Joint height h^a [mm]	Load bearing capacity [kN]	Load bearing capacity [kN]	Load bearing capacity solid plastic tyres [kg/mm]
FS 50/20	30	10 (±5)	53	140	20	90	35	3
FS 50/35	30	10 (±5)	53	140	35	90	35	3
FS 50/50	30	10 (±5)	53	140	50	90	35	3
FS 50/90	30	10 (±5)	53	138	90	90	35	3

Production length: 4 m

Standard colour: Aluminium

Larger installation heights on request.

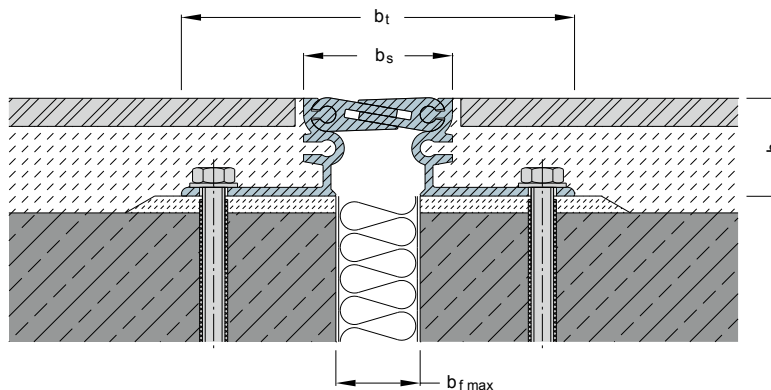



Official test certificate on load capacity available

- 1 Visible surface has no gaps**
avoids dirt accumulation
- 2 Striated surface**
ensures good skid resistance
- 3 Articulated telescoping system**
absorbs movement in 3 directions
- 4 Solid all-metal expansion joint**
hard wearing, maintenance-free, long lasting
- 5 MultiHole mounting bracket**
for secure fixing

Expansion joint cover	Joint width max. b_f [mm]	Total movement Δb_f [mm]	Visible width b_s [mm]	Joint width total b_t [mm]	Joint height h^a [mm]	Load bearing capacity [kN]	Load bearing capacity [kN]	Load bearing capacity solid plastic tyres [kg/mm]
FS 75/22	50	20 (± 10)	77	193	22	300	100	9
FS 75/30	50	20 (± 10)	77	193	30	300	100	9
FS 75/42	50	20 (± 10)	77	197	42	300	100	9
FS 75/52	50	20 (± 10)	77	197	52	300	100	9
FS 75/62	50	20 (± 10)	77	197	62	300	100	9
FS 75/77	50	20 (± 10)	77	197	77	300	70	9
FS 75/87	50	20 (± 10)	77	197	87	300	70	9
FS 75/97	50	20 (± 10)	77	197	97	300	70	9

Production length: 4 m

Standard colour: Aluminium

Larger installation heights on request.

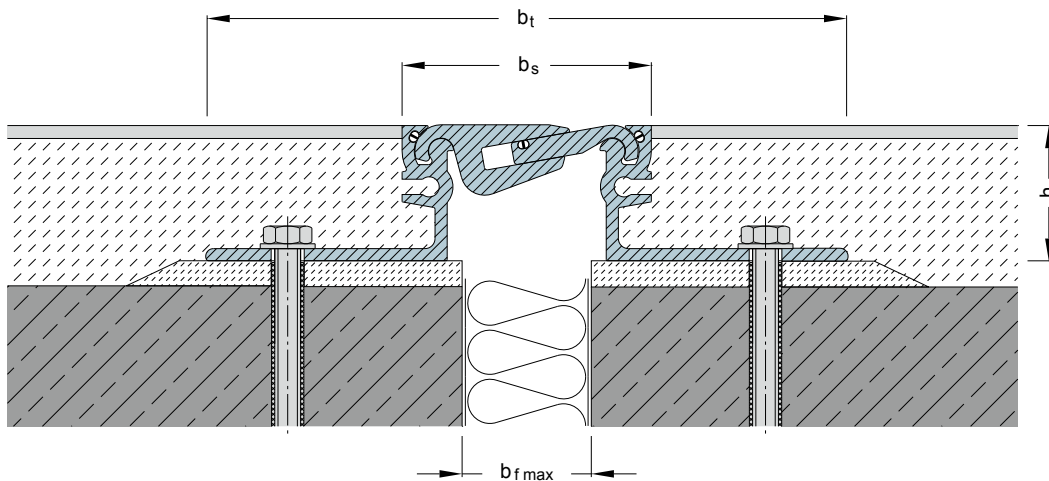

SFS 90 / 115 / 135

FOR HEAVY DUTY FLOORS

MIGUTRANS

HEAVY-DUTY ALL-METAL JOINT SOLUTIONS FOR LARGE TRAFFIC LOADS

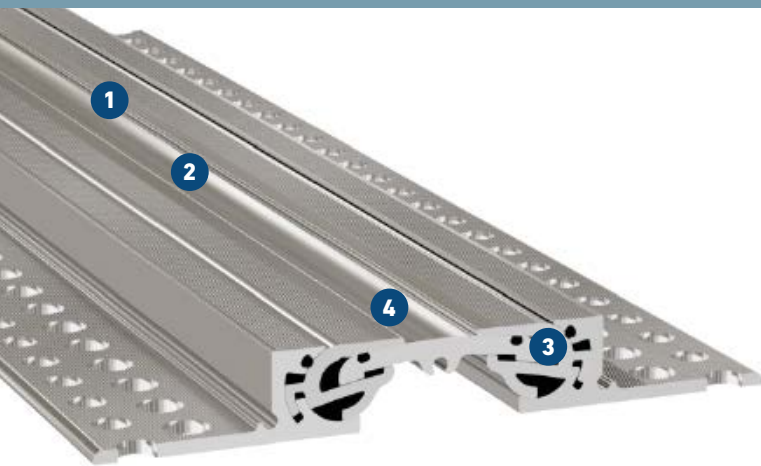

- 1 Improved transit over joints**
reduces wear on wheels
 - 2 Symmetrical visible surface**
 - 3 Super efficient design**
for smoother transit and even load distribution
 - 4 Visible surface has no gaps**
avoids dirt accumulation, easy cleaning
- Minimal vibration when trafficked**
more efficient and safer work environment

Expansion joint cover	Joint width max. b_f [mm]	Total movement Δb_f [mm]	Visible width b_s [mm]	Joint width total b_t [mm]	Joint height h^a [mm]	Load bearing capacity [kN]	Load bearing capacity [kN]	Load bearing capacity solid plastic tyres [kg/mm]
SFS 90/24	50	20 (± 10)	90	183	24	300	69(G3)	6,5
SFS 90/42	50	20 (± 10)	90	183	42	300	69(G3)	6,5
SFS 115/24	75	30 (± 15)	115	205	24	300	69(G3)	6,5
SFS 115/42	75	30 (± 15)	115	205	42	300	69(G3)	6,5
SFS 135/24	100	40 (± 20)	135	228	24	300	46(G2)	6,5
SFS 135/42	100	40 (± 20)	135	228	42	300	46(G2)	6,5

Production length: 4 m

Standard colour: Aluminium

Larger installation heights on request.

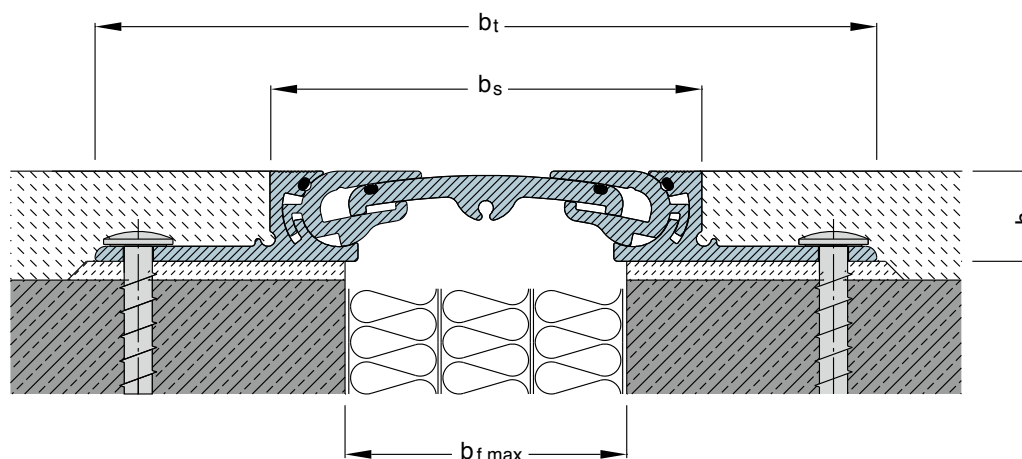

FS 99

FOR FLOORS WITH LARGE MOVEMENT – TO BE USED BY PRIVAT CARS AND PEDESTRIANS

MIGUTRANS

HEAVY-DUTY ALL-METAL JOINT SOLUTIONS FOR LARGE TRAFFIC LOADS

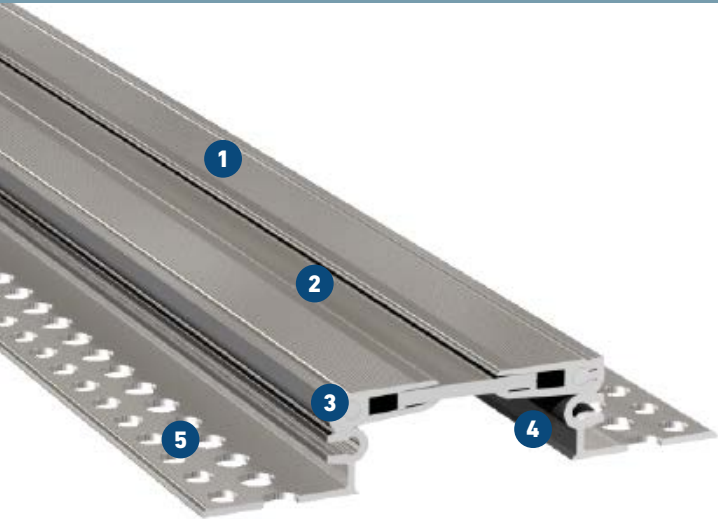

- 1 Striated surface**
ensures good skid resistance
- 2 Symmetrical visible surface shows no gaps**
avoids dirt accumulation
- 3 Articulated telescoping system**
absorbs movement in 3 directions
- 4 Solid all-metal expansion joint**
hard wearing, maintenance-free, long lasting
- 5 MultiHole mounting bracket**
for secure fixing

Expansion joint cover	Joint width max. b_f [mm]	Total movement Δb_f [mm]	Visible width b_s [mm]	Joint width total b_t [mm]	Joint height h_a [mm]	Load bearing capacity  [kN]
FS 99/20	70	40 (± 20)	99	186	20	12
FS 99/35	70	40 (± 20)	99	186	35	12
FS 99/50	70	40 (± 20)	99	186	50	12
FS 99/90	70	40 (± 20)	99	184	90	12

Production length: 4 m

Standard colour: Aluminium

Larger installation heights on request.

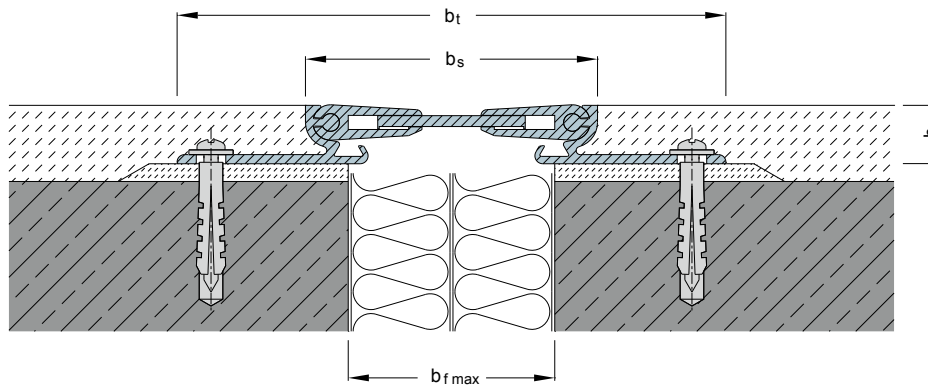

FSL 104

FOR FLOORS WITH LARGE MOVEMENTS AND REGULAR LOADS

MIGUTRANS

HEAVY-DUTY ALL-METAL JOINT SOLUTIONS FOR LARGE TRAFFIC LOADS



- 1 Solid all-metal expansion joint**
hard wearing, maintenance-free, long lasting
- 2 Striated surface**
ensures good skid resistance
- 3 Visible surface has no gaps**
avoids dirt accumulation
- 4 Articulated telescoping system**
absorbs movement in 3 directions
- 5 MultiHole mounting bracket**
for secure fixing

Expansion joint cover	Joint width max. b_f [mm]	Total movement Δb_f [mm]	Visible width b_s [mm]	Joint width total b_t [mm]	Joint height h^a [mm]	Load bearing capacity [kN]	Load bearing capacity [kN]	Load bearing capacity solid plastic tyres [kg/mm]
FSL 104/20	80	40 (± 20)	104	191	20	90	35	3,5
FSL 104/35	80	40 (± 20)	104	191	35	90	35	3,5
FSL 104/50	80	40 (± 20)	104	191	50	90	35	3,5
FSL 104/90	80	40 (± 20)	104	189	90	90	35	3,5

Production length: 4 m

Standard colour: Aluminium

Larger installation heights on request.

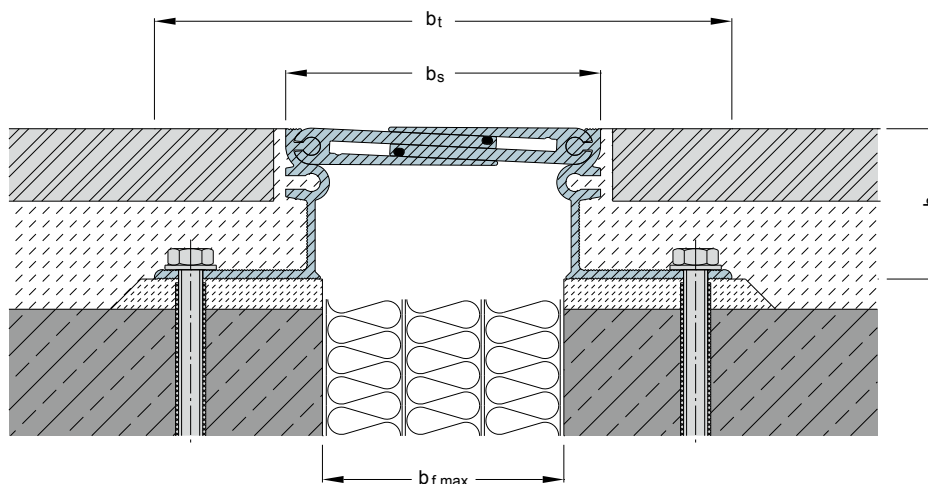

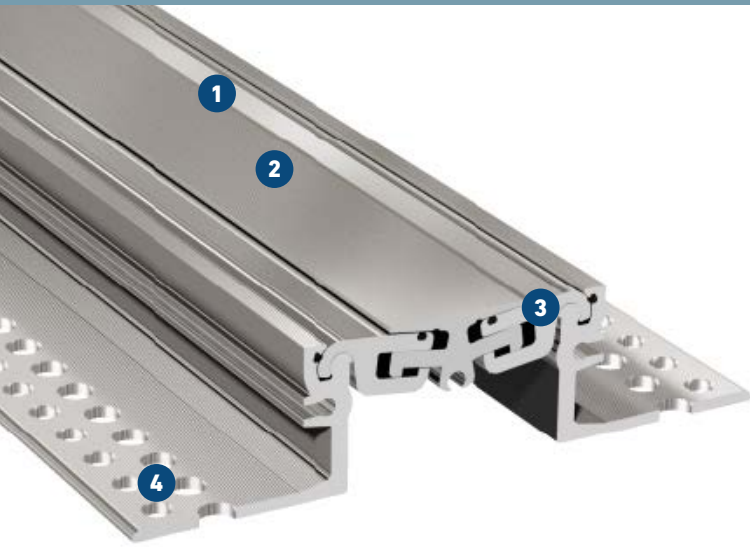

- 1** Symmetrical visible surface has no gaps
avoids dirt accumulation
- 2** Solid all-metal expansion joint
hard wearing, maintenance-free, long lasting
- 3** Articulated telescoping system
absorbs movement in 3 directions
- 4** MultiHole mounting bracket
for secure fixing

Expansion joint cover	Joint width max.	Total movement	Visible width	Joint width total	Joint height	Load bearing capacity	Load bearing capacity	Load bearing capacity
	b_f [mm]	Δb_f [mm]	b_s [mm]	b_t [mm]	h^a [mm]	[kN]	[kN]	solid plastic tyres [kg/mm]
FS 105/22*	75	20 (± 10)	105	221	22	600	130	15
FS 105/30	75	20 (± 10)	105	221	30	600	130	15
FS 105/42	75	20 (± 10)	107	223	42	600	130	15
FS 105/52	75	20 (± 10)	107	223	52	600	130	15
FS 105/62	75	20 (± 10)	107	223	62	600	130	15

* Minimum joint width 75 mm.

Production length: 4 m

Standard colour: Aluminium

Larger installation heights on request.

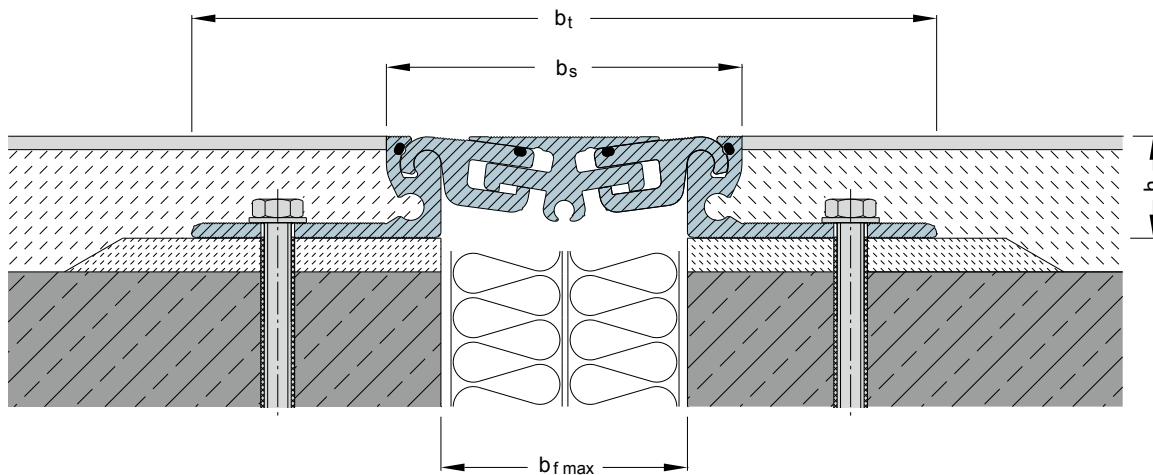

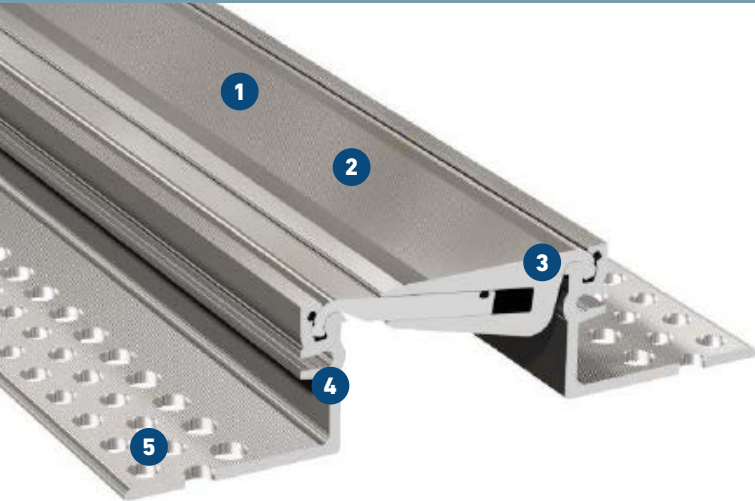

- 1 Visible surface has no gaps**
avoids dirt accumulation
- 2 Striated surface**
ensures good skid resistance
- 3 Articulated telescoping system**
absorbs movement in 3 directions
- 4 Solid all-metal expansion joint**
hard wearing, maintenance-free, long lasting
- 5 MultiHole mounting bracket**
for secure fixing

Expansion joint cover	Joint width max.	Total movement	Visible width	Joint width total	Joint height	Load bearing capacity	Load bearing capacity	Load bearing capacity
	b_f [mm]							
FS 110/22*	75	30 (±15)	110	226	22	300	70	6,5
FS 110/30	75	30 (±15)	110	226	30	300	70	6,5
FS 110/42	75	30 (±15)	110	230	42	300	70	6,5
FS 110/52	75	30 (±15)	110	230	52	300	70	6,5
FS 110/62	75	30 (±15)	110	230	62	300	70	6,5
FS 110/77	75	30 (±15)	110	230	77	300	70	6,5
FS 110/87	75	30 (±15)	110	230	87	300	70	6,5
FS 110/97	75	30 (±15)	110	230	97	300	70	6,5

* Minimum joint width 75 mm.

Production length: 4 m

Standard colour: Aluminium

Larger installation heights on request.

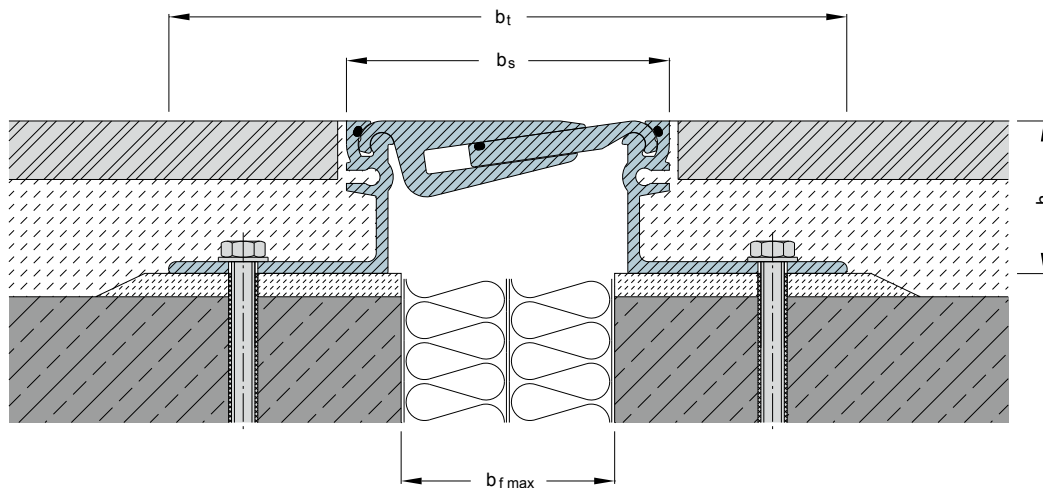

FS 110 ES



FOR HEAVY DUTY FLOORS

MIGUTRANS

HEAVY-DUTY ALL-METAL JOINT SOLUTIONS FOR LARGE TRAFFIC LOADS



- 1** **Stainless Steel, brass or 3M tape surface**
for highest demands and skid resistance (R9 - R13)
- 2** **Visible surface has no gaps**
avoids dirt accumulation
- 3** **Articulated telescoping system**
absorbs movement in 3 directions
- 4** **Solid all-metal expansion joint**
hard wearing, maintenance free, long lasting

Expansion joint cover	Joint width max.	Total movement	Visible width	Joint width total	Joint height	Load bearing capacity	Load bearing capacity	Load bearing capacity
	b_f [mm]	Δb_f [mm]	b_s [mm]	b_t [mm]	h^a [mm]	 [kN]	 [kN]	 solid plastic tyres [kg/mm]
FS 110/22 ES*	75	30 (±15)	113	226	23	300	70	6,5
FS 110/30 ES	75	30 (±15)	113	226	31	300	70	6,5
FS 110/42 ES	75	30 (±15)	113	230	43	300	70	6,5
FS 110/52 ES	75	30 (±15)	113	230	53	300	70	6,5
FS 110/62 ES	75	30 (±15)	113	230	63	300	70	6,5
FS 110/77 ES	75	30 (±15)	113	230	78	300	70	6,5
FS 110/87 ES	75	30 (±15)	113	230	88	300	70	6,5
FS 110/97 ES	75	30 (±15)	113	230	98	300	70	6,5

* Minimum joint width 75 mm.

Production length: 4 m, metal inserts: 2 x 2 m

Standard colour: aluminum, inserts: stainless steel, brass or black

Larger installation heights on request. Also available with different inserts.

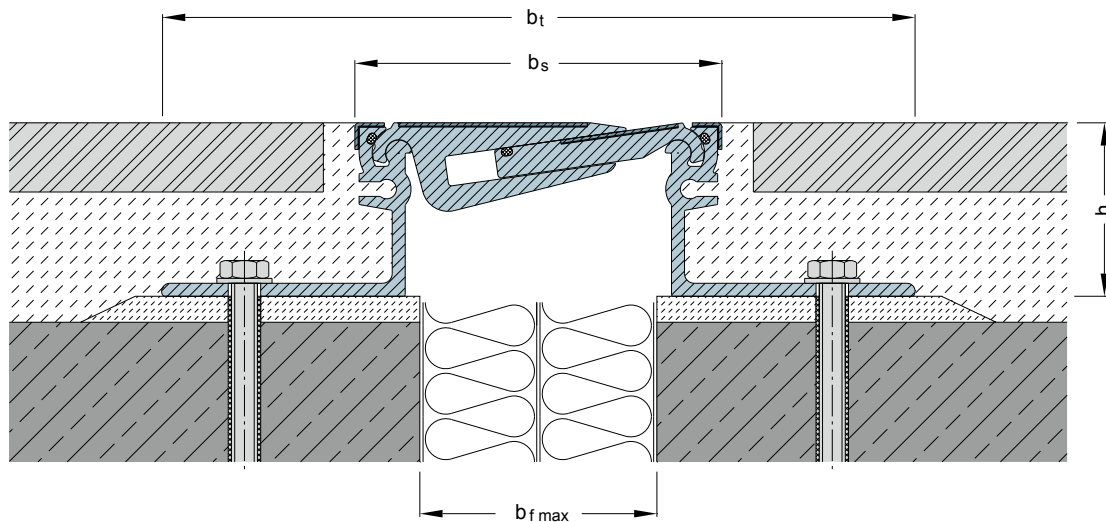

FS 130

FOR HEAVY DUTY FLOORS

MIGUTRANS

HEAVY-DUTY ALL-METAL JOINT SOLUTIONS FOR LARGE TRAFFIC LOADS



- 1 Solid all-metal expansion joint**
hard wearing, maintenance-free, long lasting
- 2 Striated surface**
ensures good skid resistance
- 3 Visible surface has no gaps**
avoids dirt accumulation
- 4 Articulated telescoping system**
absorbs movement in 3 directions
- 5 MultiHole mounting bracket**
for secure fixing

Expansion joint cover	Joint width max. b_f [mm]	Total movement Δb_f [mm]	Visible width b_s [mm]	Joint width total b_t [mm]	Joint height h^a [mm]	Load bearing capacity [kN]	Load bearing capacity [kN]	Load bearing capacity solid plastic tyres [kg/mm]
FS 130/22*	100	40 (± 20)	134	250	22	300	70	6,5
FS 130/30*	100	40 (± 20)	134	250	30	300	70	6,5
FS 130/42	100	40 (± 20)	134	254	42	300	70	6,5
FS 130/52	100	40 (± 20)	134	254	52	300	70	6,5
FS 130/62	100	40 (± 20)	134	254	62	300	70	6,5
FS 130/77	100	40 (± 20)	134	254	77	300	70	6,5
FS 130/87	100	40 (± 20)	134	254	87	300	70	6,5
FS 130/97	100	40 (± 20)	134	254	97	300	70	6,5

* Minimum joint width 100 mm

Production length: 4 m

Standard colour: Aluminium

Larger installation heights on request.

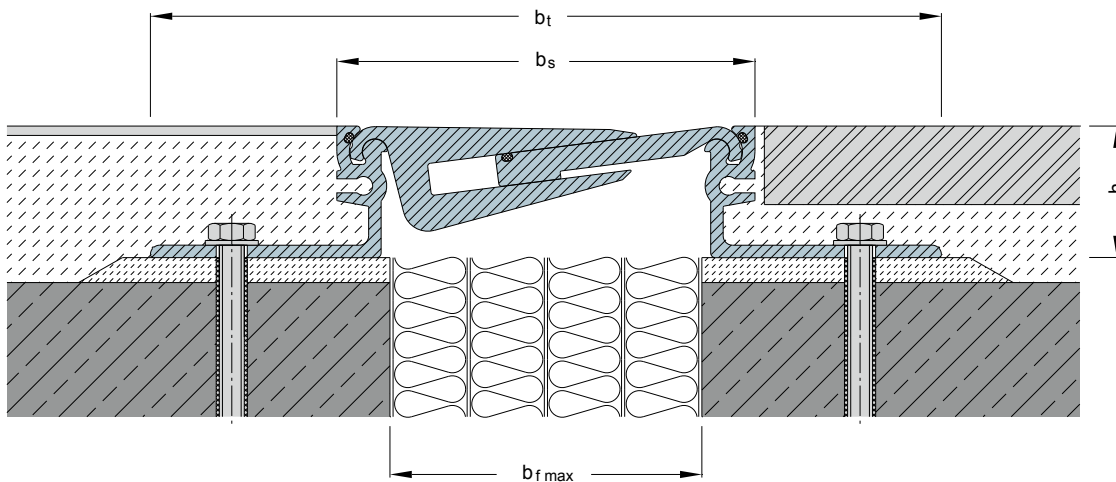

FS 135 / FS 174

FOR HEAVY DUTY FLOORS

MIGUTRANS

HEAVY-DUTY ALL-METAL JOINT SOLUTIONS FOR LARGE TRAFFIC LOADS

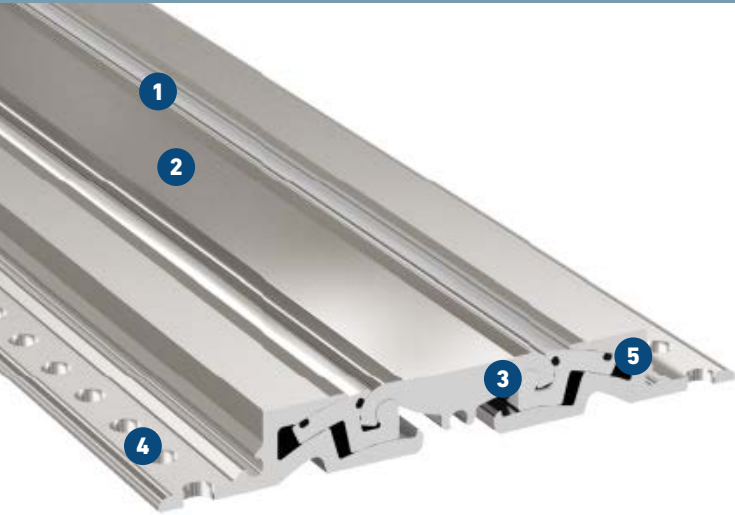

- 1** **Symmetrical visible surface has no gaps**
avoids dirt accumulation, fast cleaning
- 2** **Striated surface**
ensures good skid resistance
- 3** **Solid all-metal expansion joint**
hard wearing, maintenance-free, long lasting
- 4** **Extremely flat 25 mm**
- 5** **Articulated telescoping system**
absorbs movement in 3 directions

Expansion joint cover	Joint width max. b_f [mm]	Total movement Δb_f [mm]	Visible width b_s [mm]	Joint width total b_t [mm]	Joint height h^a [mm]	Load bearing capacity [kN]	Load bearing capacity [kN]	Load bearing capacity solid plastic tyres [kg/mm]
FS 135/25	35	20 (± 10)	135	206	25	600	250	30
FS 174/25	70	20 (± 10)	174	245	25	600	130	15

Production length: 4 m

Standard colour: Aluminium

We recommend installation using epoxy adhesive

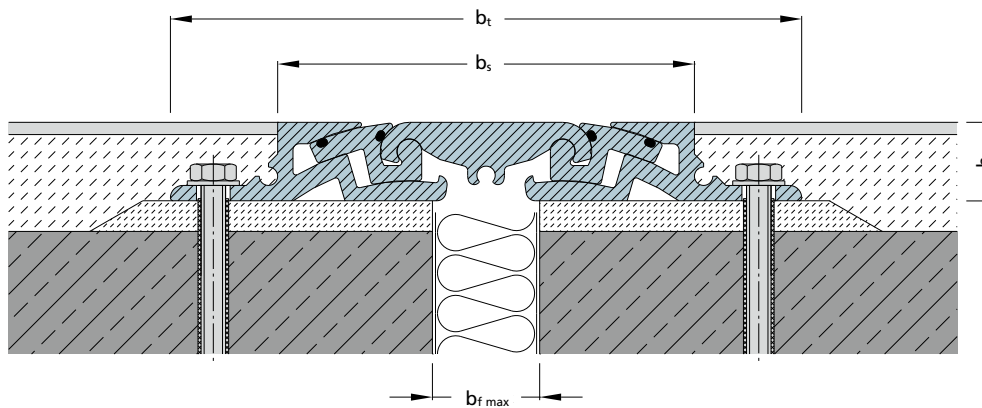

FS 146

FOR FLOORS WITH LARGE MOVEMENT – TO BE USED BY PRIVATE CARS AND PEDESTRIANS

MIGUTRANS

HEAVY-DUTY ALL-METAL JOINT SOLUTIONS FOR LARGE TRAFFIC LOADS



- 1 Solid all-metal expansion joint**
hard wearing, maintenance-free, long lasting
- 2 Striated surface**
ensures good skid resistance
- 3 Symmetrical visible surface has no gaps**
avoids dirt accumulation
- 4 Articulated telescoping system**
absorbs movement in 3 directions
- 5 MultiHole mounting bracket**
for secure fixing

Expansion joint cover	Joint width max. b_f [mm]	Total movement Δb_f [mm]	Visible width b_s [mm]	Joint width total b_t [mm]	Joint height h_a [mm]	Load bearing capacity  [kN]
FS 146/22	114	50 (±25)	146	262	22	12
FS 146/30	114	50 (±25)	146	262	30	12
FS 146/42	114	50 (±25)	146	266	42	12
FS 146/52	114	50 (±25)	146	266	52	12
FS 146/62	114	50 (±25)	146	266	62	12
FS 146/77	114	50 (±25)	146	266	77	12
FS 146/87	114	50 (±25)	146	266	87	12
FS 146/97	114	50 (±25)	146	266	97	12

Production length: 4 m

Standard colour: Aluminium

Larger installation heights on request.

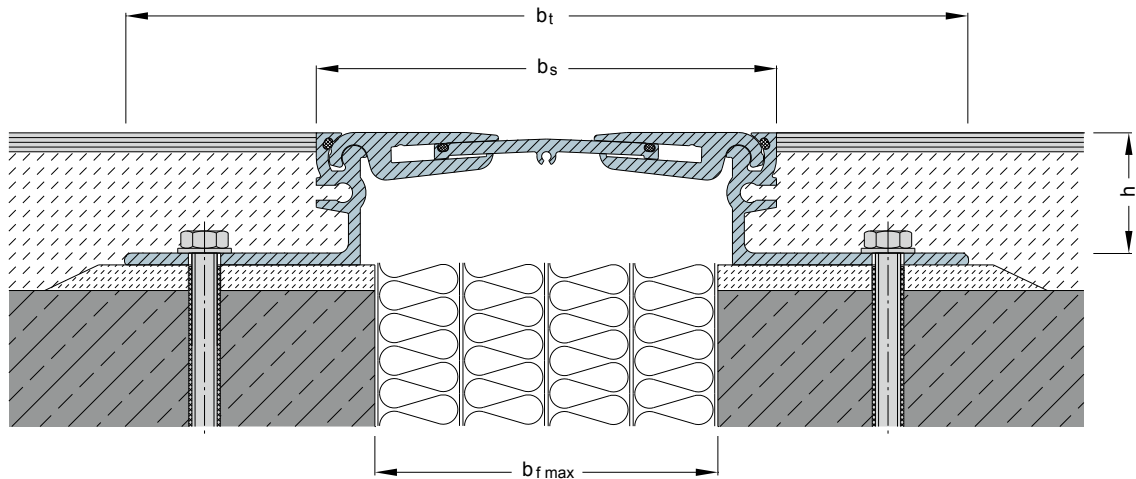

FS 155

FOR HEAVY DUTY FLOORS

MIGUTRANS

HEAVY-DUTY ALL-METAL JOINT SOLUTIONS FOR LARGE TRAFFIC LOADS



- 1** **Symmetrical visible surface has no gaps**
avoids dirt accumulation
- 2** **Striated surface**
ensures good skid resistance
- 3** **Articulated telescoping system**
absorbs movement in 3 directions
- 4** **Solid all-metal expansion joint**
hard wearing, maintenance-free, long lasting
- 5** **MultiHole mounting bracket**
for secure fixing

Expansion joint cover	Joint width max.	Total movement	Visible width	Joint width total	Joint height	Load bearing capacity	Load bearing capacity	Load bearing capacity
	b_f [mm]	Δb_f [mm]	b_s [mm]	b_t [mm]	h^a [mm]	[kN]	[kN]	solid plastic tyres [kg/mm]
FS 155/22*	120	40(±20)	155	271	22	600	130	15
FS 155/30	120	40(±20)	155	271	30	600	130	15
FS 155/42	120	40(±20)	157	273	42	600	130	15
FS 155/52	120	40(±20)	157	273	52	600	130	15
FS 155/62	120	40(±20)	157	273	62	600	130	15

* Minimum joint width 120 mm

Production length: 4 m

Standard colour: Aluminium

Larger installation heights on request.

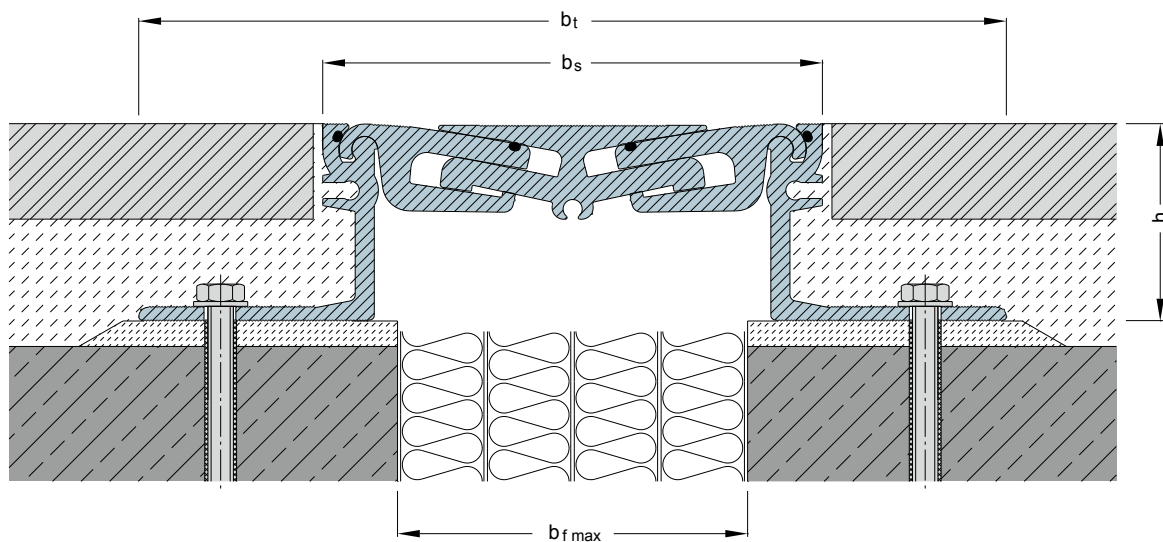

FS 160

FOR HEAVY DUTY FLOORS

MIGUTRANS

HEAVY-DUTY ALL-METAL JOINT SOLUTIONS FOR LARGE TRAFFIC LOADS

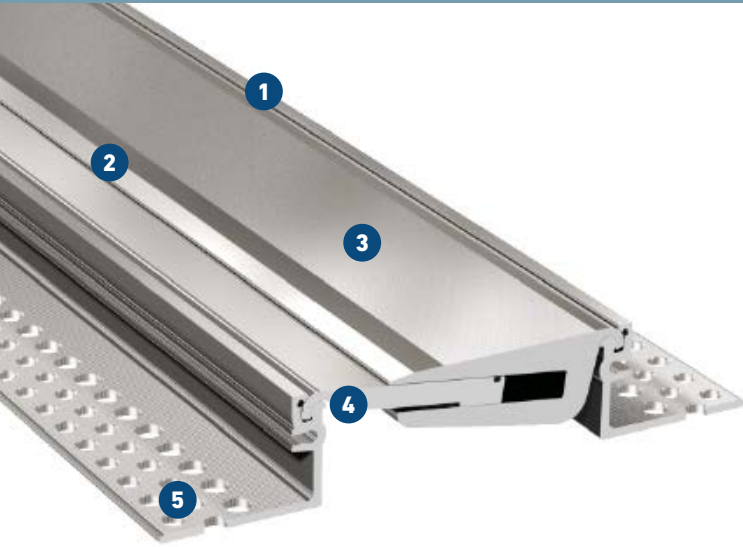

- 1 Solid all-metal expansion joint**
hard wearing, maintenance-free, long lasting
- 2 Visible surface has no gaps**
avoids dirt accumulation
- 3 Striated surface**
ensures good skid resistance
- 4 Articulated telescoping system**
absorbs movement in 3 directions
- 5 MultiHole mounting bracket**
for secure fixing

Expansion joint cover	Joint width max. b_f [mm]	Total movement Δb_f [mm]	Visible width b_s [mm]	Joint width total b_t [mm]	Joint height h^a [mm]	Load bearing capacity [kN]	Load bearing capacity [kN]	Load bearing capacity solid plastic tyres [kg/mm]
FS 160/22*	130	60 (± 30)	162	280	22	300	70	6,5
FS 160/30*	130	60 (± 30)	162	280	30	300	70	6,5
FS 160/42	130	60 (± 30)	162	284	42	300	70	6,5
FS 160/52	130	60 (± 30)	162	284	52	300	70	6,5
FS 160/62	130	60 (± 30)	162	284	62	300	70	6,5
FS 160/77	130	60 (± 30)	162	284	77	300	70	6,5
FS 160/87	130	60 (± 30)	162	284	87	300	70	6,5
FS 160/97	130	60 (± 30)	162	284	97	300	70	6,5

* Minimum joint width 130 mm

Production length: 4 m

Standard colour: Aluminium

Larger installation heights on request.

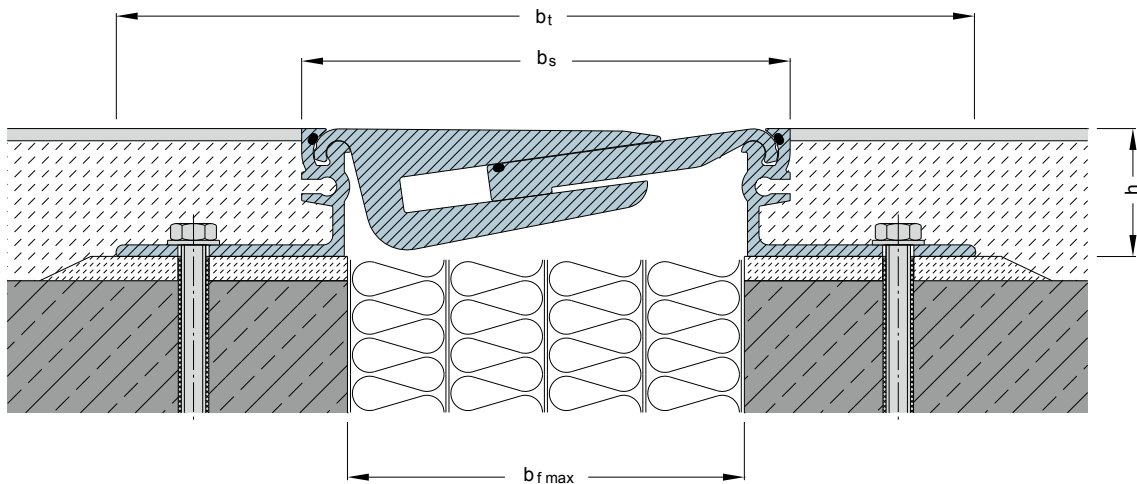

FS 185

FOR HEAVY DUTY FLOORS

MIGUTRANS

HEAVY-DUTY ALL-METAL JOINT SOLUTIONS FOR LARGE TRAFFIC LOADS



- 1 Visible surface has no gaps**
avoids dirt accumulation
- 2 Striated surface**
ensures good skid resistance
- 3 Extremely flat (27 mm)**
ideal for redevelopment, refurbishment, renovation
- 4 Articulated telescoping system**
absorbs movement in 3 directions
- 5 Solid all-metal expansion joint**
hard wearing, maintenance-free, long lasting

MultiHole mounting bracket
for secure fixing

Expansion joint cover	Joint width max. b_f [mm]	Total movement Δb_f [mm]	Visible width b_s [mm]	Joint width total b_t [mm]	Joint height h^a [mm]	Load bearing capacity [kN]	Load bearing capacity [kN]	Load bearing capacity solid plastic tyres [kg/mm]
FS 185/27	140	60 (± 30)	185	305	27	300	70	6,5
FS 185/40	140	60 (± 30)	185	305	40	300	70	6,5
FS 185/80	140	60 (± 30)	185	305	80	300	70	6,5

Production length: 3 m

Standard colour: Aluminium

Larger installation heights on request.

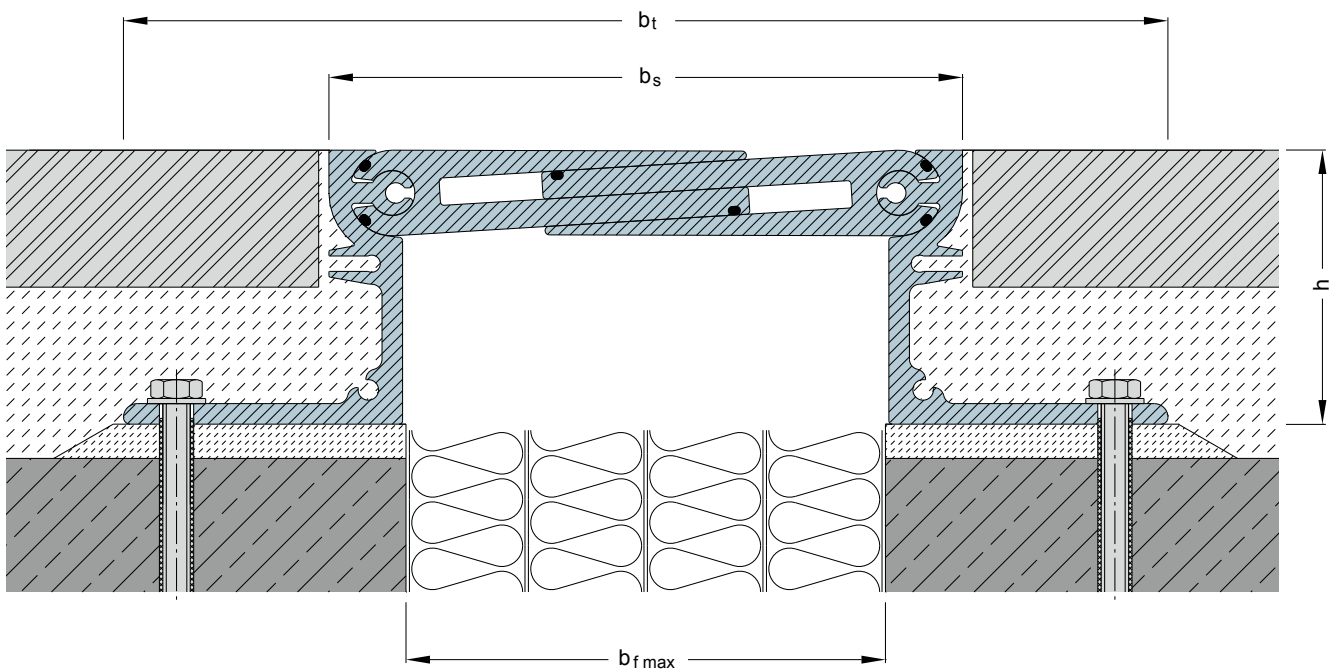

FSV 235

FOR HEAVY DUTY FLOORS

MIGUTRANS

HEAVY-DUTY ALL-METAL JOINT SOLUTIONS FOR LARGE TRAFFIC LOADS



- 1 Visible surface has no gaps**
avoids dirt accumulation
- 2 Removable bridging unit**
serviceable for inspection, replaceable centre parts
- 3 Striated surface**
ensures good skid resistance
- 4 Articulated telescoping system**
absorbs movement in 3 directions
- 5 Solid all-metal expansion joint**
hard wearing, maintenance-free, long lasting

Expansion joint cover	Joint width max. b_f [mm]	Total movement Δb_f [mm]	Visible width b_s [mm]	Joint width total b_t [mm]	Joint height h^a [mm]	Load bearing capacity [kN]	Load bearing capacity [kN]	Load bearing capacity solid plastic tyres [kg/mm]
FSV 235/45	150	60 (± 30)	235	357	45	300	70	6,5
FSV 235/80	150	60 (± 30)	235	357	80	300	70	6,5
FSV 235/130	150	60 (± 30)	235	357	130	300	70	6,5

Production length: 3 m
Standard colour: Aluminium
 Alternative heights on request.

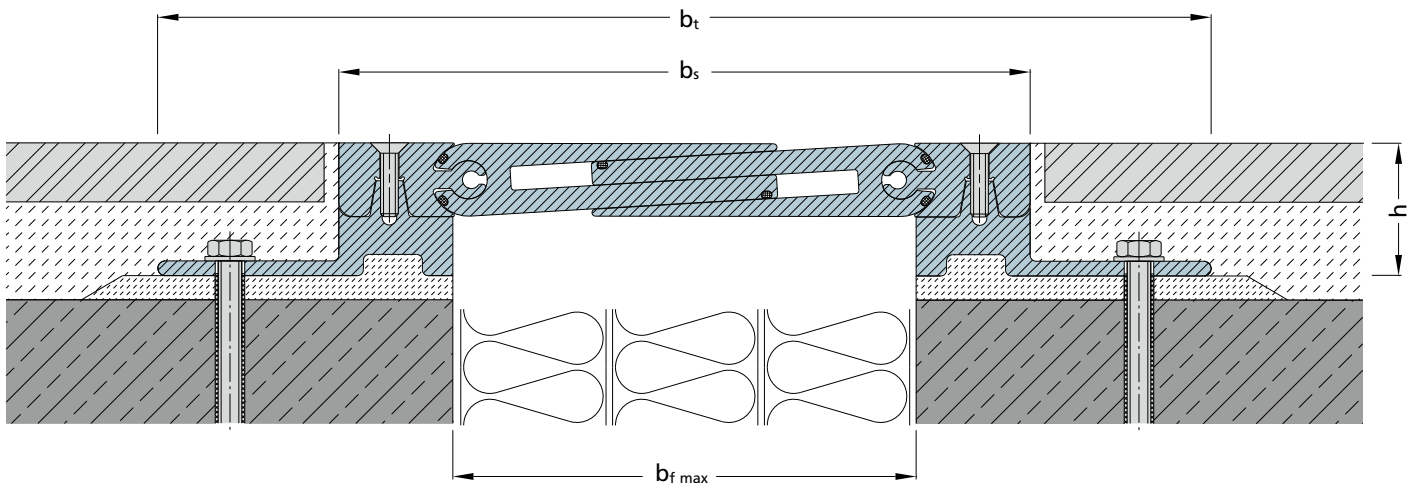

FSV 280

FOR HEAVY DUTY FLOORS

MIGUTRANS

HEAVY-DUTY ALL-METAL JOINT SOLUTIONS FOR LARGE TRAFFIC LOADS

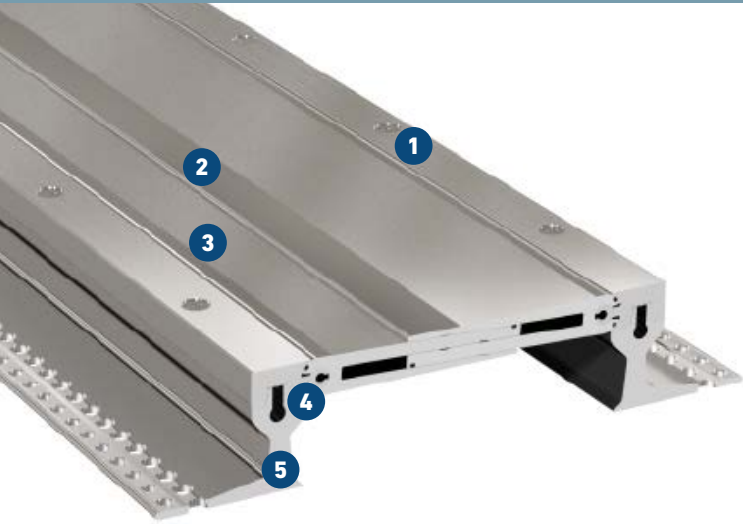

- 1 Removable bridging unit**
serviceable for inspection, replaceable centre parts
- 2 Visible surface has no gaps**
avoids dirt accumulation
- 3 Striated surface**
ensures good skid resistance
- 4 Articulated telescoping system**
absorbs movement in 3 directions
- 5 Solid all-metal expansion joint**
hard wearing, maintenance-free, long lasting

Expansion joint cover	Joint width max. b_f [mm]	Total movement Δb_f [mm]	Visible width b_s [mm]	Joint width total b_t [mm]	Joint height h^a [mm]	Load bearing capacity [kN]	Load bearing capacity [kN]	Load bearing capacity solid plastic tyres [kg/mm]
FSV 280/45	200	85 (± 42.5)	280	403	45	35	35	6,5
FSV 280/80	200	85 (± 42.5)	280	403	80	35	35	6,5
FSV 280/130	200	85 (± 42.5)	280	403	130	35	35	6,5

Production length: 3 m

Standard colour: Aluminium

Larger installation heights on request.

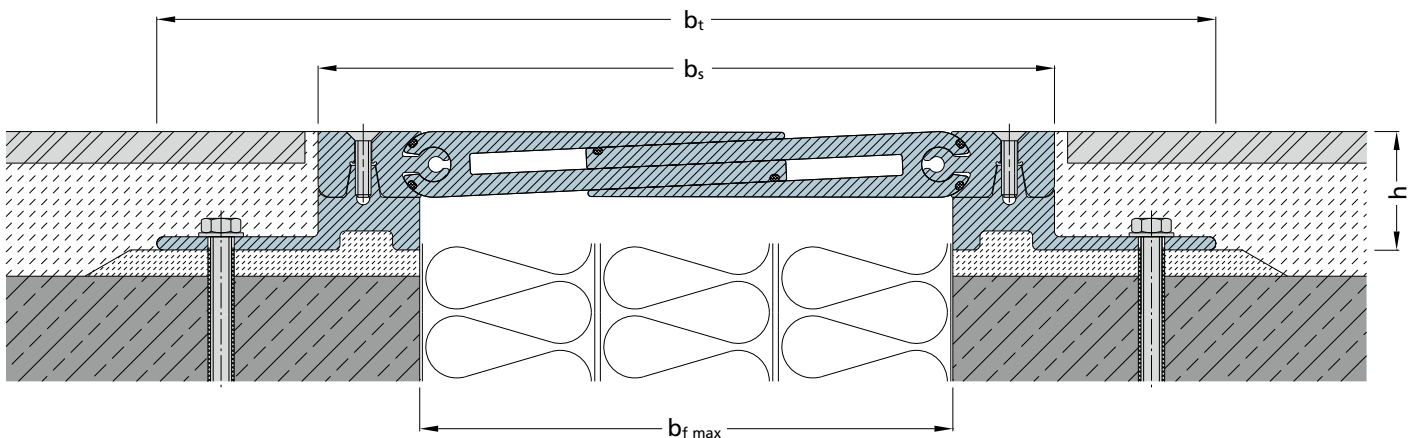

FSV 285

FOR HEAVY DUTY FLOORS

MIGUTRANS

HEAVY-DUTY ALL-METAL JOINT SOLUTIONS FOR LARGE TRAFFIC LOADS



- 1 Solid all-metal expansion joint**
hard wearing, maintenance-free, long lasting
- 2 Symmetrical visible surface has no gaps**
avoids dirt accumulation
- 3 Extremely flat (27 mm)**
ideal for redevelopment
- 4 MultiHole mounting bracket**
for secure fixing
- 5 Articulated telescoping system**
absorbs movement in 3 directions

Expansion joint cover	Joint width max. b_f [mm]	Total movement Δb_f [mm]	Visible width b_s [mm]	Joint width total b_t [mm]	Joint height h_a [mm]	Load bearing capacity  [kN]
FSV 285/27	240	100 (±50)	284	404	27	35
FSV 285/40	240	100 (±50)	284	404	40	35
FSV 285/80	240	100 (±50)	284	404	80	35

Production length: 3 m

Standard colour: Aluminium

Larger installation heights on request.

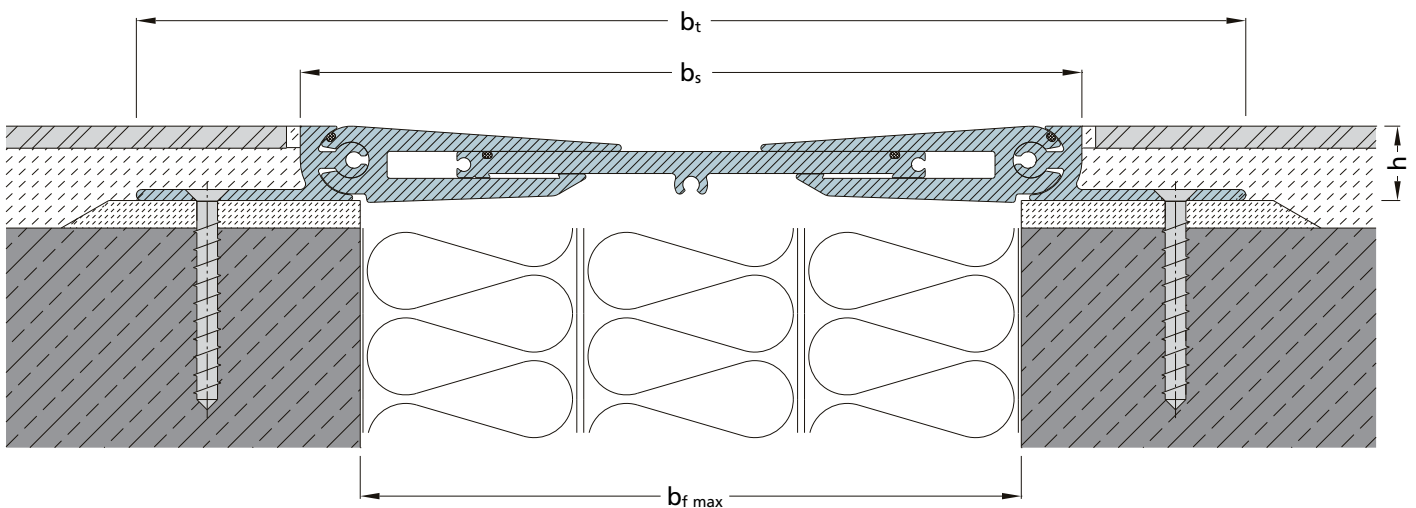

FSV 335

FOR HEAVY DUTY FLOORS

MIGUTRANS

HEAVY-DUTY ALL-METAL JOINT SOLUTIONS FOR LARGE TRAFFIC LOADS

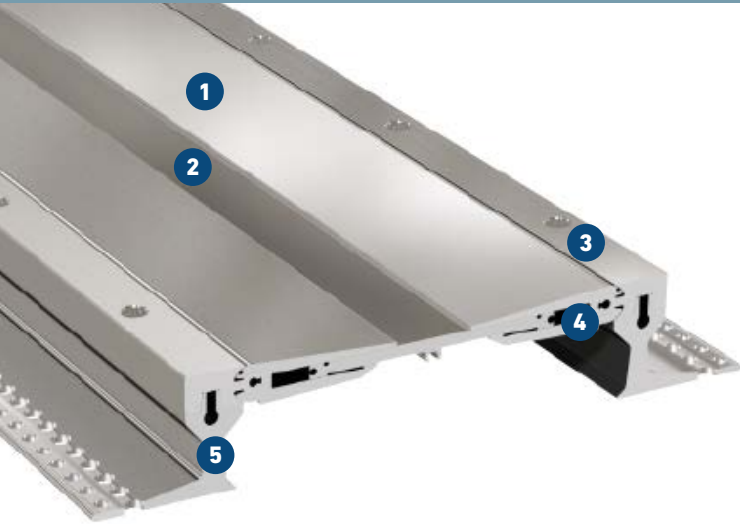

- 1 Striated surface**
ensures good skid resistance
- 2 Symmetrical visible surface has no gaps**
avoids dirt accumulation
- 3 Removable bridging unit**
serviceable for inspection, replaceable centre parts
- 4 Articulated telescoping system**
absorbs movement in 3 directions
- 5 Solid all-metal expansion joint**
hard wearing, maintenance-free, long lasting

Expansion joint cover	Joint width max. b_f [mm]	Total movement Δb_f [mm]	Visible width b_s [mm]	Joint width total b_t [mm]	Joint height h_a [mm]	Load bearing capacity  [kN]
FSV 335/45	250	100 (±50)	335	457	45	35
FSV 335/80	250	100 (±50)	335	457	80	35
FSV 335/130 *	250	100 (±50)	335	457	130	35

Production length: 3 m

Standard colour: Aluminium

Alternative heights on request.

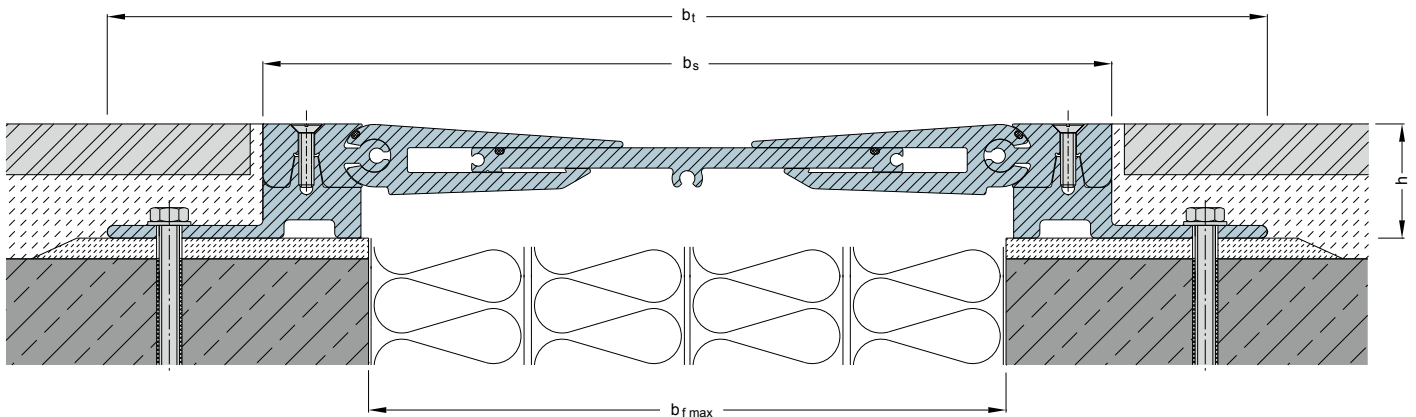

FS 220 / FS 260 / FS 380



FOR FLOORS WITH SMALL INSTALLATION HEIGHTS

MIGUTRANS

HEAVY-DUTY ALL-METAL JOINT SOLUTIONS FOR LARGE TRAFFIC LOADS



- 1** **Symmetrical visible surface has no gaps**
avoids dirt accumulation
- 2** **Striated surface**
ensures good skid resistance
- 3** **Extremely flat, fixing without arms**
ideal for redevelopment, refurbishment, renovation
- 4** **Articulated telescoping system**
absorbs movement in 3 directions
- 5** **Solid all-metal expansion joint**
hard wearing, maintenance-free, long lasting

Expansion joint cover	Joint width max. b_f [mm]	Total movement Δb_f [mm]	Visible width b_s [mm]	Joint width total b_t [mm]	Joint height h^a [mm]	Load bearing capacity  [kN]	Load bearing capacity  [kN]	Load bearing capacity  solid plastic tyres [kg/mm]
FS 220/20	60	40 (± 20)	220	220	21	600	130	15
FS 260/20	100	40 (± 20)	260	260	21	600	130	15
FS 380/20	215	40 (± 20)	378	378	21	300	70	15

Production length: 3 m

Standard colour: Aluminium

We recommend fixing with Multi-Monti Stainless steel screws MMS F 7,5 x 95/30 ES (available ex stock), fixing distance: 200 mm.

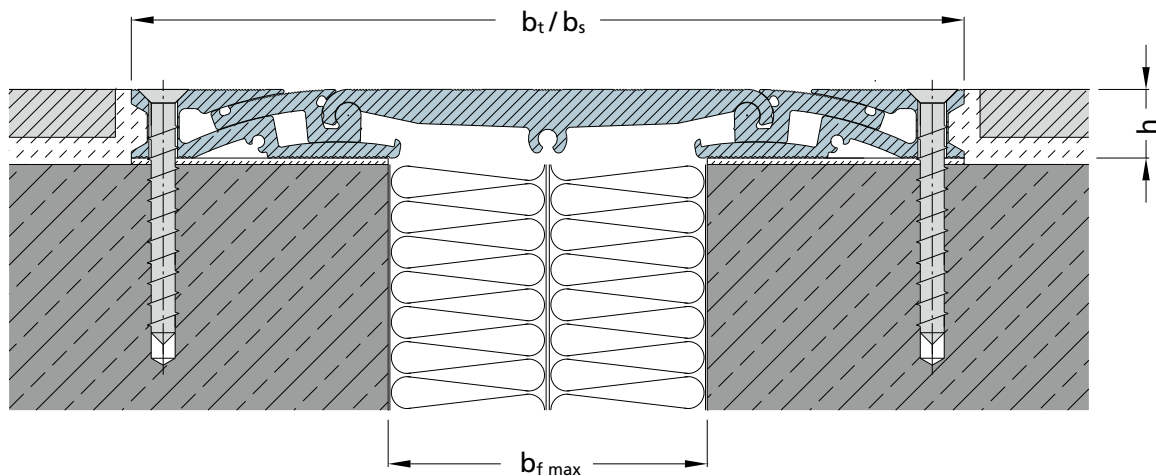

FS 255 / FS 295 / FS 410

FOR FLOORS WITH SMALL INSTALLATION HEIGHTS

MIGUTRANS

HEAVY-DUTY ALL-METAL JOINT SOLUTIONS FOR LARGE TRAFFIC LOADS



- 1 Removable**
without destruction of the adjacent floor
- 2 Symmetrical visible surface has no gaps**
avoids dirt accumulation
- 3 Extremely flat, fixing without arms**
ideal for redevelopment, refurbishment, renovation
- 4 Articulated telescoping system**
absorbs movement in 3 directions
- 5 Solid all-metal expansion joint**
hard wearing, maintenance-free, long lasting

Expansion joint cover	Joint width max. b_f [mm]	Total movement Δb_f [mm]	Visible width b_s [mm]	Joint width total b_t [mm]	Joint height h^a [mm]	Load bearing capacity [kN]	Load bearing capacity [kN]	Load bearing capacity solid plastic tyres [kg/mm]
FS 255/30	50	60 (± 30)	253	253	30	600	130	15
FS 295/30	90	60 (± 30)	293	293	30	600	130	15
FS 410/30	205	60 (± 30)	410	410	30	300	70	15

Production length: 3 m

Standard colour: Aluminium, FS 410: Aluminium anodized

We recommend fixing with Stainless steel Multi-Monti Screws MMS F 7,5 x 115/50 ES (available ex stock), fixing distance: 200 mm.

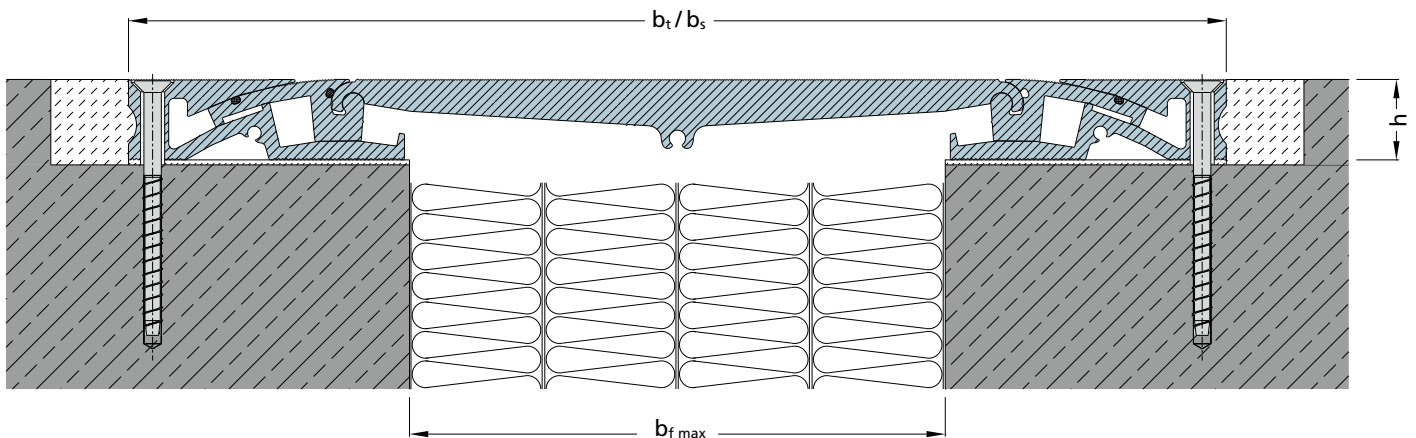

FSN 50

ALL-METAL EXPANSION JOINT. FOR SUBSEQUENT INSTALLATION

MIGUTRANS

HEAVY-DUTY ALL-METAL JOINT SOLUTIONS FOR LARGE TRAFFIC LOADS



- 1 Solid all-metal expansion joint**
hard wearing, maintenance-free, long lasting
- 2 Visible surface has no gaps**
avoids dirt accumulation
- 3 Striated surface**
ensures good skid resistance
- 4 Articulated telescoping system**
absorbs movement in 3 directions

Ideal for redevelopment, refurbishment, renovation

Expansion joint cover	Joint width min. [mm]	Total movement Δb_f [mm]	Visible width b_s [mm]	Joint width total b_t [mm]	Installation height h_a [mm]	Thickness of alu side plates h_1 [mm]	Load bearing capacity 
FSN 50	55	10 (± 5)	173	173	3	15	pedestrians

* Light vehicles on request.

Production length: 4 m

Standard colour: Aluminium

Mounting distance: 300 mm

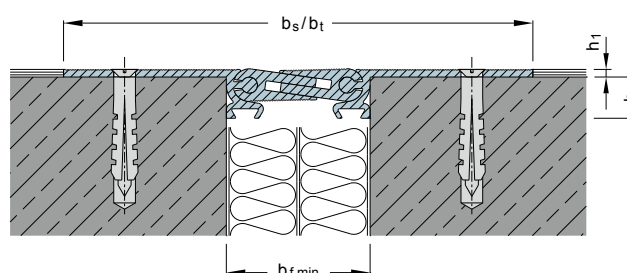

FSN 99

ALL-METAL EXPANSION JOINT. FOR SUBSEQUENT INSTALLATION

MIGUTRANS

HEAVY-DUTY ALL-METAL JOINT SOLUTIONS FOR LARGE TRAFFIC LOADS



- 1 Solid all-metal expansion joint**
hard wearing, maintenance-free, long lasting
- 2 Symmetrical visible surface has no gaps**
avoids dirt accumulation
- 3 Striated surface**
ensures good skid resistance
- 4 Articulated telescoping system**
absorbs movement in 3 directions

Ideal for redevelopment, refurbishment, renovation

Expansion joint cover	Joint width min. [mm]	Total movement Δb_f [mm]	Visible width b_s [mm]	Joint width total b_t [mm]	Installation height h_a [mm]	Thickness of alu side plates h_1 [mm]	Load bearing capacity 
FSN 99	100	40 (± 20)	219	219	15	3	pedestrians

* Light vehicles on request.

Production length: 4 m

Standard colour: Aluminium

Mounting distance: 300 mm

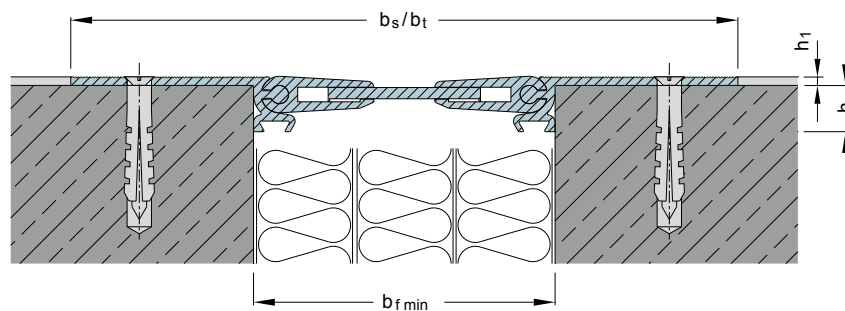

FSN 146

ALL-METAL EXPANSION JOINT. FOR SUBSEQUENT INSTALLATION

MIGUTRANS

HEAVY-DUTY ALL-METAL JOINT SOLUTIONS FOR LARGE TRAFFIC LOADS



- 1 Solid all-metal expansion joint**
hard wearing, maintenance-free, long lasting
- 2 Symmetrical visible surface has no gaps**
avoids dirt accumulation
- 3 Striated surface**
ensures good skid resistance
- 4 Articulated telescoping system**
absorbs movement in 3 directions

Expansion joint cover	Joint width min. [mm]	Total movement Δb_f [mm]	Visible width b_s [mm]	Joint width total b_t [mm]	Installation height h^a [mm]	Thickness of alu side plates h_1 [mm]	Load bearing capacity  [kN]
FSN 146	153	50 (± 25)	390	390	21	6,3	12

Production length: 4 m

Standard colour: Aluminium

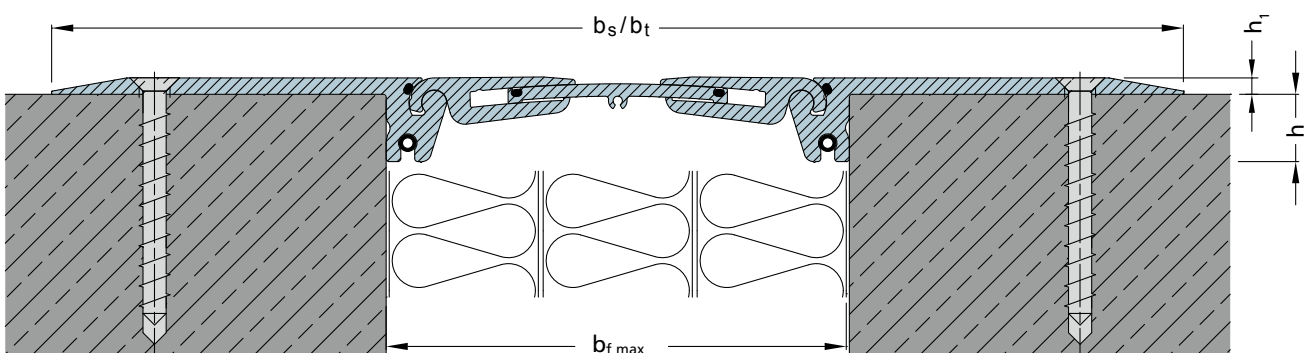

Installation instructions:

Any unevenness in the surface to which the expansion joint is being fixed must be remedied by using an epoxy adhesive e.g. Reckli-Adhesive EP. The aluminium brackets must then be fixed at both sides with countersunk stainless steel screws e.g. Multi Monti type MMS7,5 ES or similar, at 200 mm intervals.





- 1 Solid all-metal expansion joint**
hard wearing, maintenance-free, long lasting
- 2 Visible surface has no gaps**
avoids dirt accumulation
- 3 Striated surface**
ensures good skid resistance
- 4 Articulated telescoping system**
absorbs movement in 3 directions

Expansion joint cover	Joint width min. [mm]	Total movement Δb_f [mm]	Visible width b_s [mm]	Joint width total b_t [mm]	Installation height h_a [mm]	Thickness of alu side plates h_1 [mm]	Load bearing capacity  [kN]	Load bearing capacity  [kN]	Load bearing capacity  solid plastic tyres [kg/mm]
FSN 46 *	50	20 (± 10)	276	276	21	6,3	90	35	6,5
FSN 75	84	20 (± 10)	320	320	21	6,3	90	35	6,5
FSN 105	112	20 (± 10)	348	348	25	6,3	90	35	6,5
FSN 110	118	30 (± 15)	354	354	21	6,3	90	35	6,5
FSN 130	142	40 (± 20)	378	378	28	6,3	90	35	6,5
FSN 155	162	40 (± 20)	398	398	24	6,3	90	35	6,5
FSN 160	170	60 (± 30)	406	406	34	6,3	90	35	6,5
FSN 185	200	60 (± 30)	409	409	18	6,3	90	35	6,5
FSN 280	240	85 ($\pm 42,5$)	454	454	21	6,3	35	35	6,5
FSN 285	290	100 (± 50)	508	508	28	6,3	35	35	6,5

* cannot take settlements

Production length: 4 m, FSN 185, FSN 280 and FSN 285: 3 m

Standard colour: Aluminium

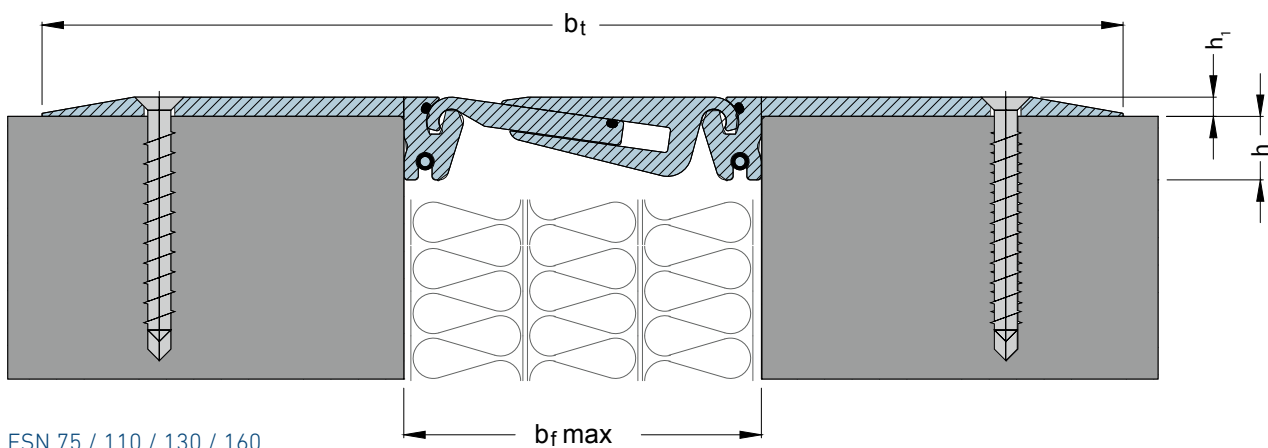

FSN 75 / 110 / 130 / 160

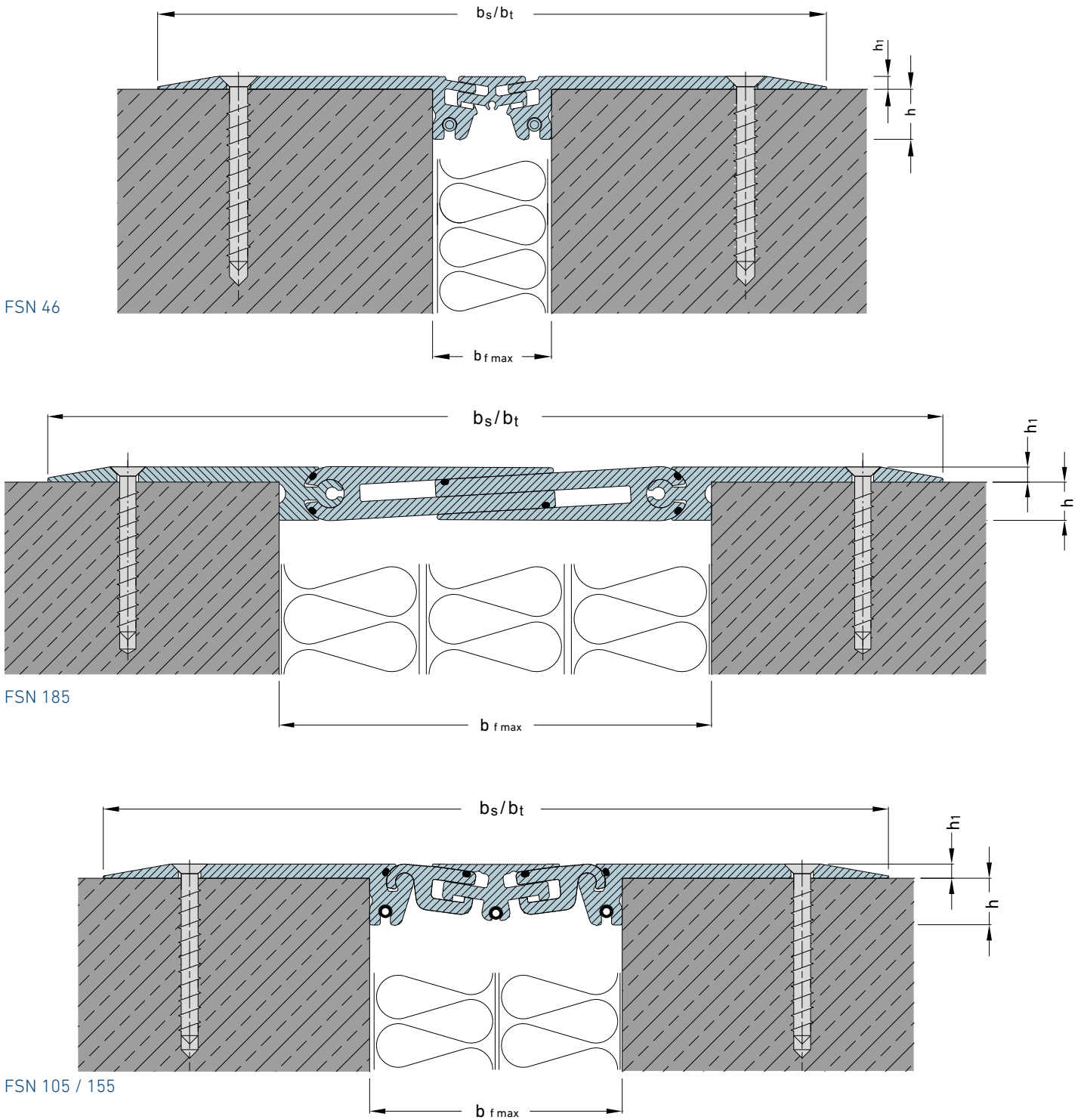

Installation instructions:

Any unevenness in the surface to which the expansion joint is being fixed must be remedied by using an epoxy adhesive e.g. Reckli-Adhesive EP. The aluminium brackets must then be fixed at both sides with countersunk stainless steel screws e.g. Multi Monti type MMS7,5 ES or similar, at 200 mm intervals.

FS 100

HEAVY DUTY EXPANSION JOINT FOR TRANSPORT FREE FROM VIBRATION

MIGUTRANS

HEAVY-DUTY ALL-METAL JOINT SOLUTIONS FOR LARGE TRAFFIC LOADS

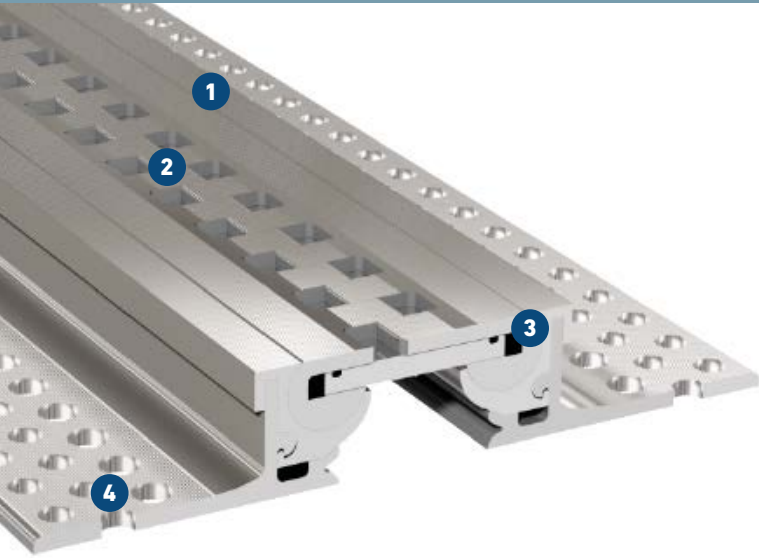

- 1 Solid all-metal expansion joint**
hard wearing, maintenance-free, long lasting
- 2 Transportation free from vibration**
suitable for transport of sensitive goods
- 3 Articulated telescoping system**
absorbs movement in 3 directions
- 4 MultiHole mounting bracket**
for secure fixing

Official test certificate on load capacity available

Expansion joint cover	Joint width max. b_f [mm]	Total movement Δb_f [mm]	Visible width b_s [mm]	Joint width total b_t [mm]	Joint height h^a [mm]	Load bearing capacity [kN]	Load bearing capacity [kN]	Load bearing capacity solid plastic tyres [kg/mm]
FS 100/30	50	20 (± 10)	102	236	30	300	75	9
FS 100/40	50	20 (± 10)	102	236	40	300	75	9
FS 100/50	50	20 (± 10)	102	236	50	300	75	9

Production length: 4 m
Standard colour: Aluminium

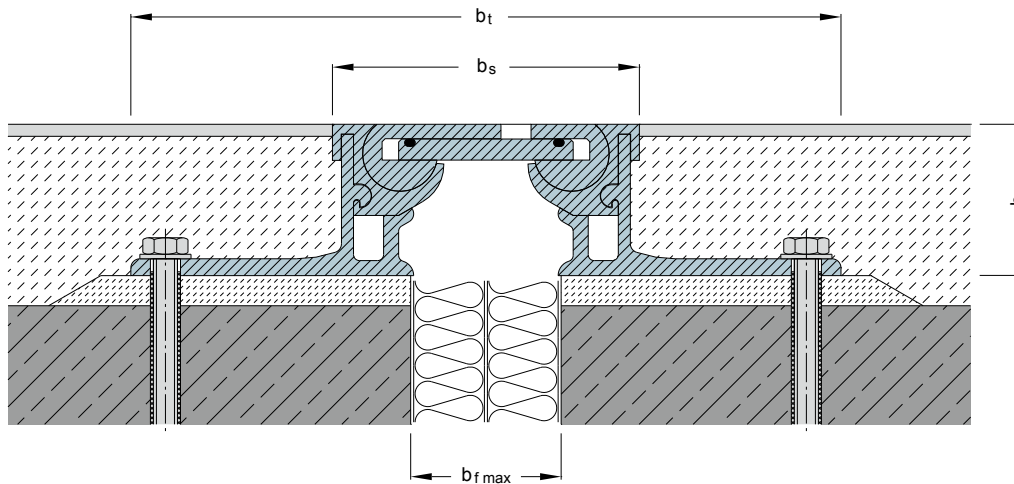

FSS 215

HEAVY DUTY EXPANSION JOINT FOR TRANSPORT FREE FROM VIBRATION

MIGUTRANS

HEAVY-DUTY ALL-METAL JOINT SOLUTIONS FOR LARGE TRAFFIC LOADS



- 1 Innovative aluminium alloy**
for highest load capacity
- 2 Extremely flat 23 mm, fixing without arms**
Time and cost saving installation, ideal for redevelopment
- 3 Transportation free from vibration from a wheel width of 100 mm**
suitable for transport of sensitive goods
- 4 Absorbs horizontal movement (transverse and parallel)**
not suitable for vertical movement
- 5 Solid all-metal expansion joint**
hard wearing, maintenance-free, long lasting

Expansion joint cover	Joint width max. b_f [mm]	Total movement Δb_f [mm]	Visible width b_s [mm]	Joint width total b_t [mm]	Joint height h^a [mm]	Load bearing capacity [kN]	Load bearing capacity [kN]	Load bearing capacity solid plastic tyres [kg/mm]
FSS 215/23	60	40 (± 20)	215	215	23	600	130	30

Production length: 3 m

Standard colour: Aluminium

We recommend fixing with galvanized Multi-Monti Screws MMS P 10 x 70 (available ex stock).

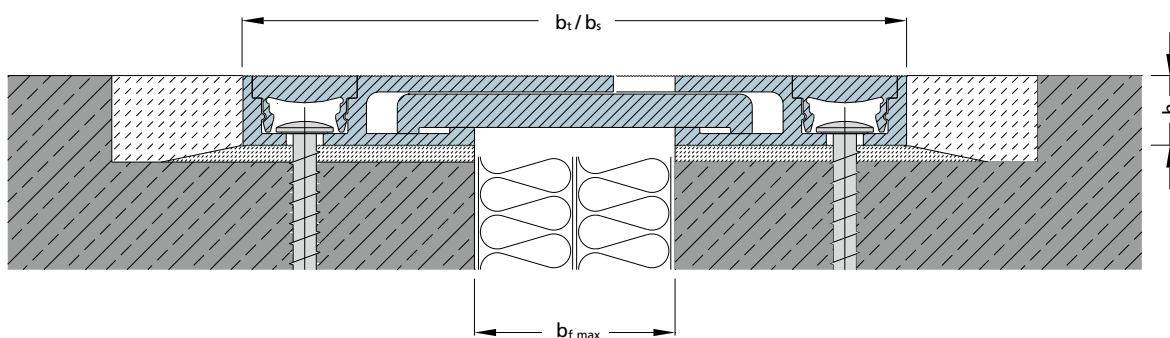

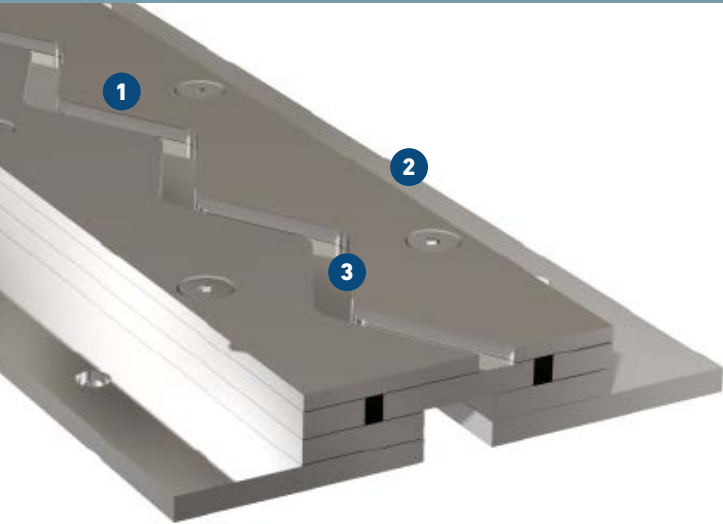

- 1 Steel-/Stainless steel-Combination**
for highest load capacity by pallet trucks, fork lift trucks, heavy lorries, special vehicles, etc.
- 2 Transportation free from vibration from a wheel width of 100 mm**
suitable for transport of sensitive goods
- 3 Absorbs horizontal movement (transverse and parallel)**
Not suitable for vertical movement

Expansion joint cover	Joint width max. b_f [mm]	Total movement Δb_f [mm]	Visible width b_s [mm]	Joint width total b_t [mm]	Joint height h^a [mm]	Load bearing capacity [kN]	Load bearing capacity [kN]	Load bearing capacity solid plastic tyres [kg/mm]
STS 100/30 ES	35	20 (± 10)	102	182	29	600	150	75
STS 100/50 ES	35	20 (± 10)	102	182	49	600	150	75
STS 100/60 ES	35	20 (± 10)	102	182	59	600	150	75

Production length: 1,96 m

Material - Visible surface: stainless steel 304 or 316Ti

Underlying construction: black steel, galvanized steel or stainless steel (please specify while ordering).

Larger joint width or movement capacity or special heights on request.

Mounting distance: 300 mm

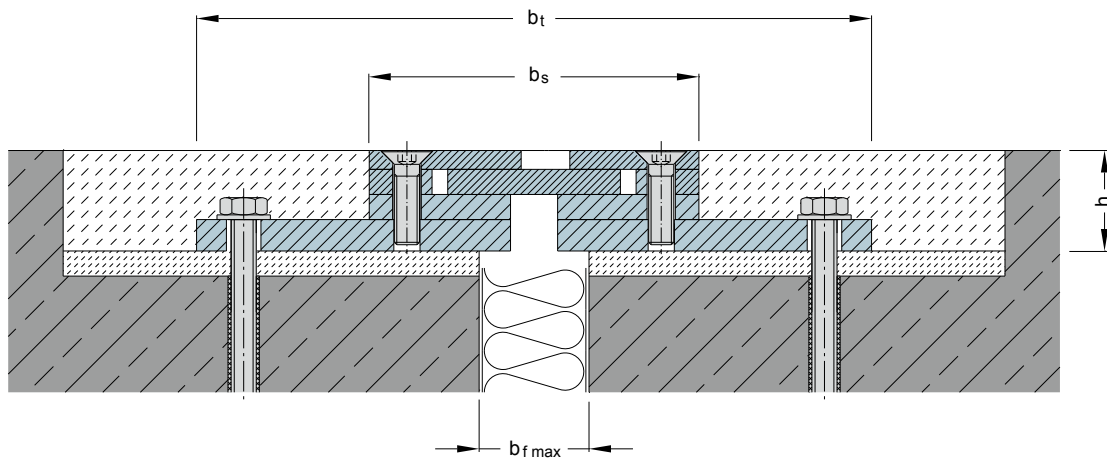

STS 160

FOR HEAVY DUTY FLOORS

MIGUTRANS

HEAVY-DUTY ALL-METAL JOINT SOLUTIONS FOR LARGE TRAFFIC LOADS



- 1 Steel-/Stainless steel-Combination**
for highest load capacity by pallet trucks, fork lift trucks, heavy lorries, special vehicles, etc.
- 2 Transportation free from vibration from a wheel width of 100 mm**
suitable for transport of sensitive goods
- 3 Absorbs horizontal movement (transverse and parallel)**
Not suitable for vertical movement

Expansion joint cover	Joint width max. b_f [mm]	Total movement Δb_f [mm]	Visible width b_s [mm]	Joint width total b_t [mm]	Joint height h^a [mm]	Load bearing capacity [kN]	Load bearing capacity [kN]	Load bearing capacity solid plastic tyres [kg/mm]
STS 160/30 ES	60	40 (± 20)	163	233	29	600	150	75
STS 160/45 ES	60	40 (± 20)	163	233	44	600	150	75
STS 160/60 ES	60	40 (± 20)	163	233	59	600	150	75

Production length: 1,96 m

Material - Visible surface: stainless steel 304 or 316Ti

Underlying construction: black steel, galvanized steel or stainless steel (please specify while ordering).

Mounting distance: 300 mm

Larger joint width or movement capacity or special heights on request.

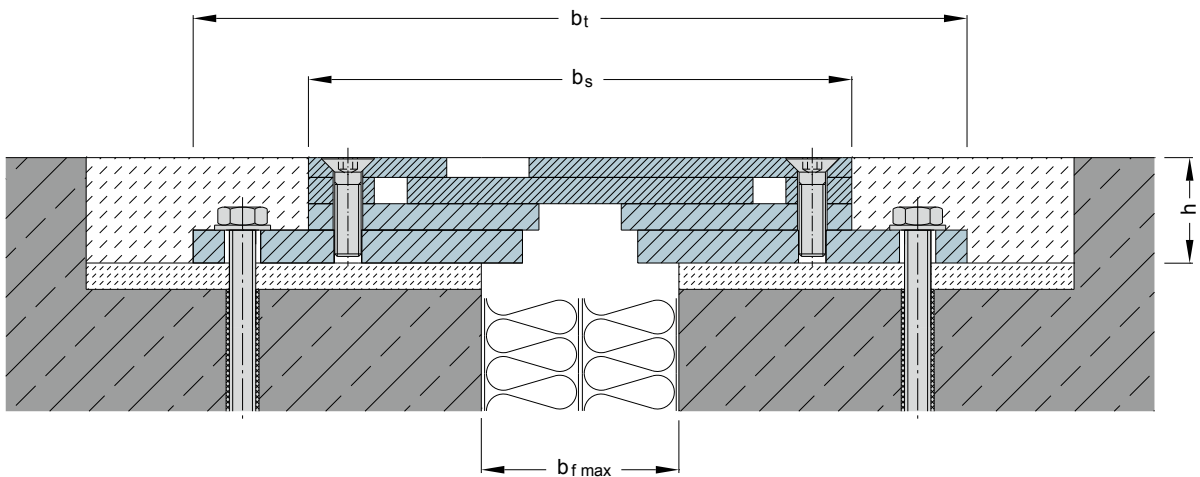

STS 160/16 / STS 160/22

FOR HEAVY DUTY FLOORS WITH SMALLER INSTALLATION HEIGHTS

MIGUTRANS

HEAVY-DUTY ALL-METAL JOINT SOLUTIONS FOR LARGE TRAFFIC LOADS



- 1 Steel-/Stainless steel-Combination**
for highest load capacity by pallet trucks, fork lift trucks, heavy lorries, special vehicles, etc.
- 2 Transportation free from vibration from a wheel width of 100 mm**
suitable for transport of sensitive goods
- 3 Extremely flat (16 mm), fixing without arms**
Time and cost saving installation, ideal for redevelopment
- 4 Absorbs horizontal movement (transverse and parallel)**
Not suitable for vertical movement

Expansion joint cover	Joint width max. b_f [mm]	Total movement Δb_f [mm]	Visible width b_s [mm]	Joint width total b_t [mm]	Joint height h^a [mm]	Load bearing capacity [kN]	Load bearing capacity [kN]	Load bearing capacity solid plastic tyres [kg/mm]
STS 160/16 ES	30	40 (± 20)	163	163	16	600	150	75
STS 160/22 ES	30	40 (± 20)	163	163	21	600	150	75

Production length: 1,96 m

Material - Visible surface: stainless steel 304 or 316Ti

Underlying construction: black steel, galvanized steel or stainless steel (please specify while ordering).

Mounting distance: 300 mm

Larger joint width or movement capacity or special heights on request.

We recommend fixing with Stainless steel Multi-Monti Screws MMS F 7,5 x 115/50 ES (available ex stock), fixing distance: 150 mm.

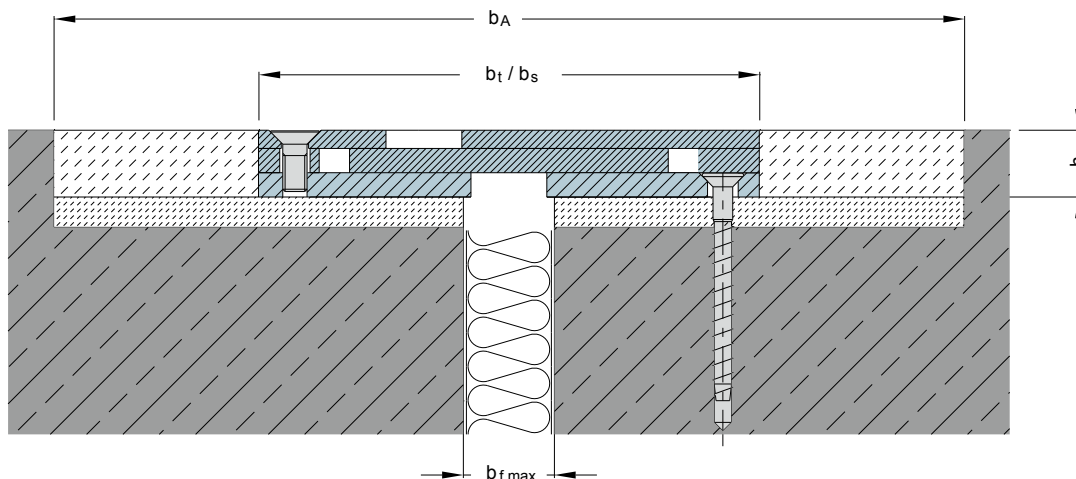

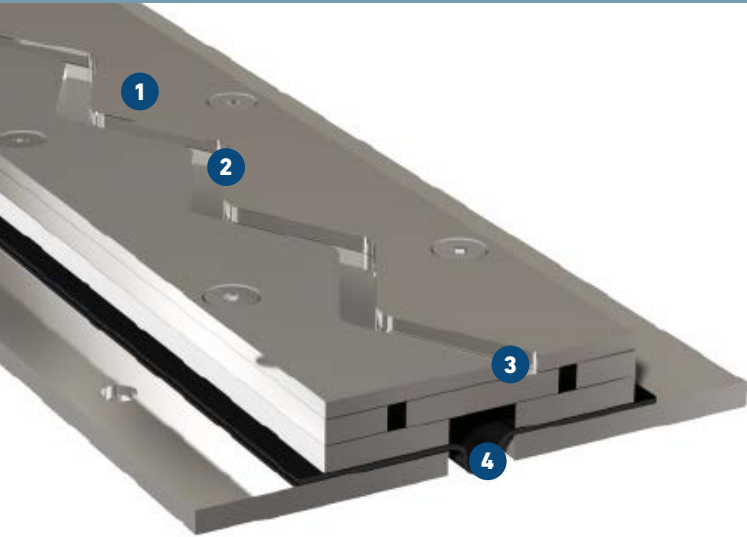

- 1 Steel-/Stainless steel-Combination**
for highest load capacity by pallet trucks, fork lift trucks, heavy lorries, special vehicles, etc.
- 2 Transportation free from vibration from a wheel width of 100 mm**
suitable for transport of sensitive goods
- 3 Absorbs horizontal movement (transverse and parallel)**
Not suitable for vertical movement
- 4 Additional sealing layer**
Watertight in connection with connection joint

Expansion joint cover	Joint width max. b_f [mm]	Total movement Δb_f [mm]	Visible width b_s [mm]	Joint width total b_t [mm]	Joint height h^a [mm]	Load bearing capacity [kN]	Load bearing capacity [kN]	Load bearing capacity solid plastic tyres [kg/mm]
STD 100/30 ES	35	20 (± 10)	102	182	31	600	150	75
STD 100/50 ES	35	20 (± 10)	102	182	51	600	150	75
STD 100/60 ES	35	20 (± 10)	102	182	61	600	150	75

Production length: 1,96 m

Sealing layer: Wolfin IB

Material - Visible surface: stainless steel 304 or 316Ti

Underlying construction: black steel, galvanized steel or stainless steel (please specify while ordering).

Larger joint width or movement capacity or special heights on request.

Mounting distance: 300 mm

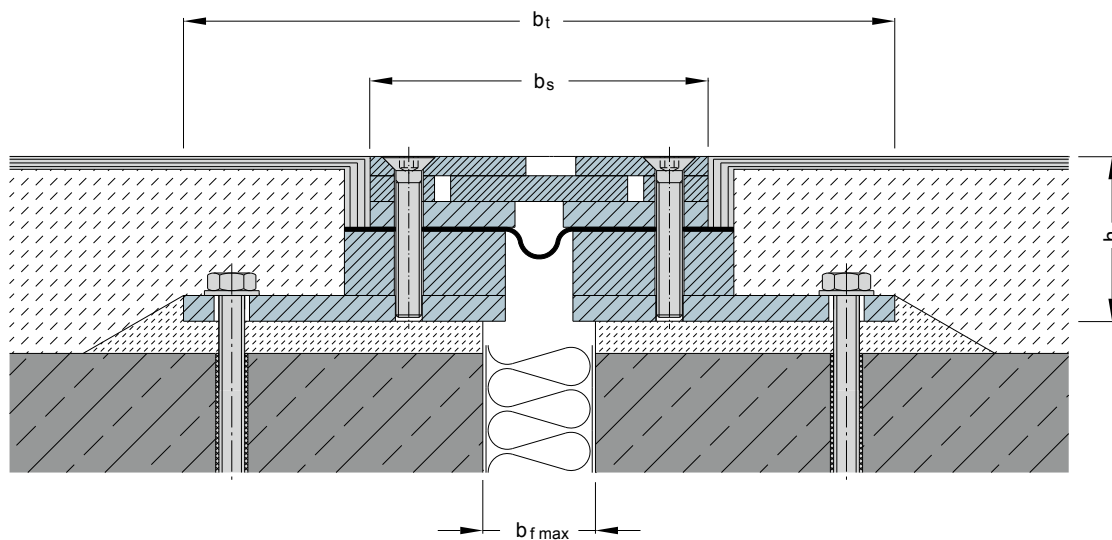

STW 160

WATERTIGHT – FOR HEAVY DUTY FLOORS

MIGUTRANS

HEAVY-DUTY ALL-METAL JOINT SOLUTIONS FOR LARGE TRAFFIC LOADS



- 1 Steel-/Stainless steel-Combination**
for highest load capacity by pallet trucks, fork lift trucks, heavy lorries, special vehicles, etc.
- 2 Transportation free from vibration from a wheel width of 100 mm**
suitable for transport of sensitive goods
- 3 Absorbs horizontal movement (transverse and parallel)**
Not suitable for vertical movement
- 4 Additional sealing layer**
Watertight in connection with connection joint

Expansion joint cover	Joint width max. b_f [mm]	Total movement Δb_f [mm]	Visible width b_s [mm]	Joint width total b_t [mm]	Joint height h^a [mm]	Load bearing capacity [kN]	Load bearing capacity [kN]	Load bearing capacity solid plastic tyres [kg/mm]
STD 160/30 ES	60	40 (± 20)	163	233	31	600	150	75
STD 160/45 ES	60	40 (± 20)	163	233	46	600	150	75
STD 160/60 ES	60	40 (± 20)	163	233	61	600	150	75

Production length: 1,96 m

Sealing layer: Wolfin IB

Material - Visible surface: stainless steel 304 or 316Ti

Underlying construction: black steel, galvanized steel or stainless steel (please specify while ordering).

Larger joint width or movement capacity or special heights on request.

Mounting distance: 300 mm

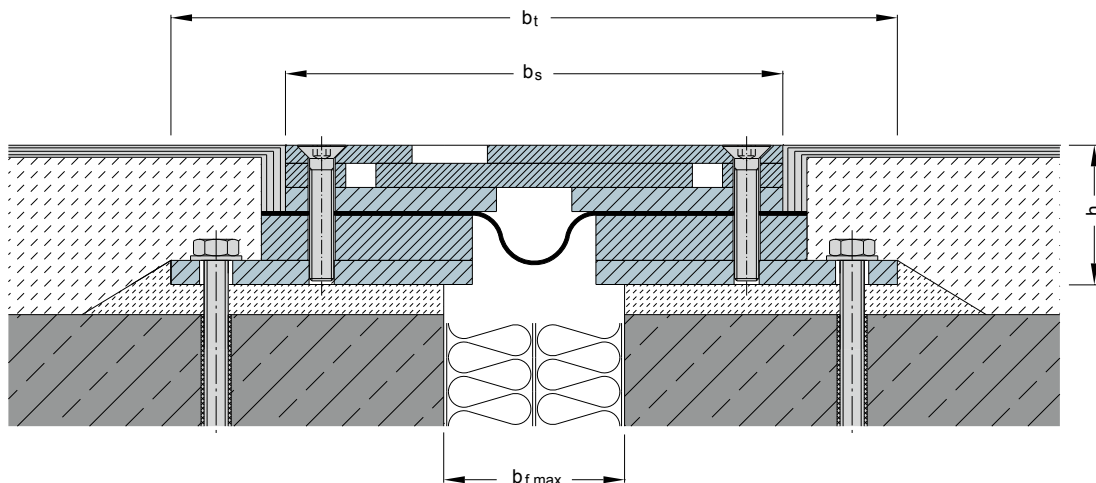

JOINT CONNECTION EXAMPLES FS

The equal height and side connection of joint lengths is carried out for one-piece expansion joint constructions using connecting pins that slide into place.

For multiple-piece expansion joint constructions, connection is carried out by sliding the connecting brackets into one another.

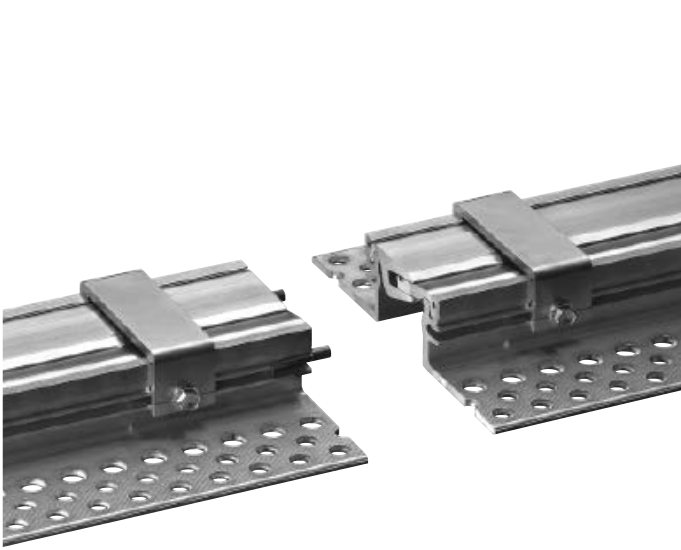

FS 75/42 (one-piece expansion joint construction)

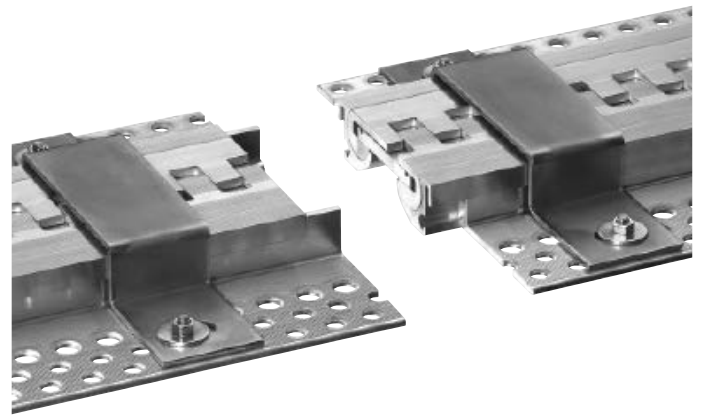

FS 100/30 (multiple-piece expansion joint construction)

MOULDED PARTS EXAMPLES



Further intersection variations are available on request

MOULDED PARTS EXAMPLES

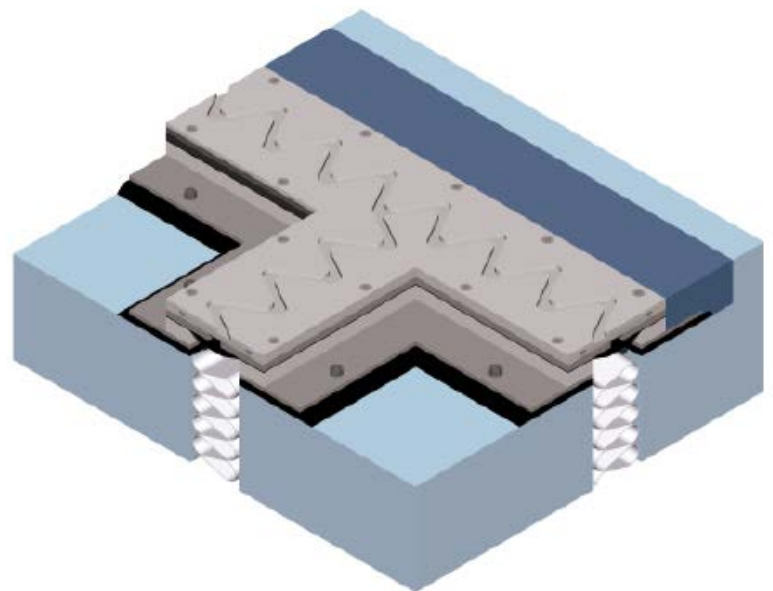
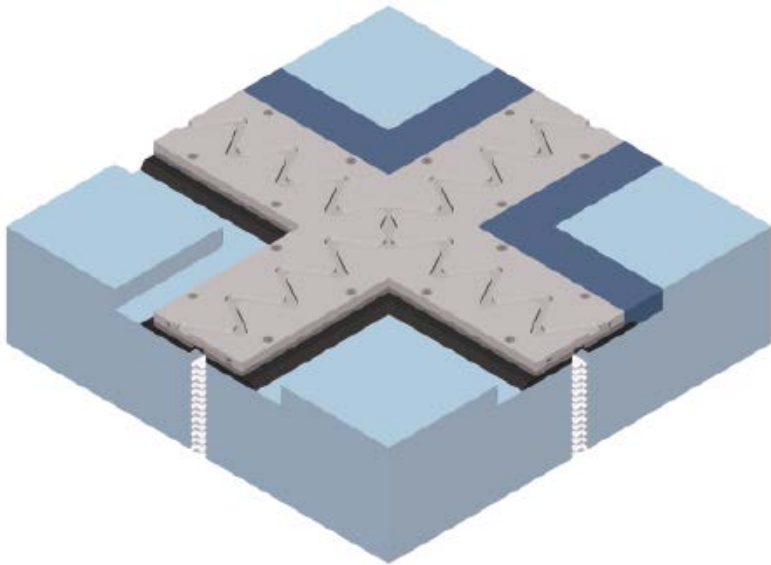

WALL-CONNECTION VERSIONS DIMENSIONS

Expansion joint cover	Joint height* h [mm]	Wall-connection version E3			Wall-connection version E4		
		b _s [mm]	b _t [mm]	Joint depth _{min} h _E [mm]	b _s [mm]	b _t [mm]	Joint depth _{min} h _E [mm]
FS 40**	19, 35, 60	40	101	35	44	105	40
FS 46**	50	48	109	35	52	113	40
FS 50	20, 35, 50	53	97	31	55	99	40
FS 75	22, 30, 42, 52, 62, 77, 87, 97	81	141	60	81	141	40
FS 99	20, 35, 50	99	143	31	101	145	40
FS 105	30, 42, 52, 62	109	169	60	109	169	40
FS 110	42, 52, 62, 77, 87, 97	114	174	60	114	174	40
FS 130	30, 42, 52, 62, 77, 87, 97	138	198	60	138	198	40
FS 146	22, 30, 42, 52, 62, 77, 87, 97	150	210	60	150	210	40
FS 155	30, 42, 52, 62	159	219	60	159	219	40
FS 160	42, 52, 62, 77, 87, 97	166	226	60	166	226	40
FS 185	27, 40, 80	186	246	75	186	246	50
FSV 235	45, 80, (90), (130), (140)	210	271	75	210	271	50
FSV 280	45, 80, (90), (130), (140)	256	317	75	256	317	50
FSV 285	27, 40, 80	284	354	75	284	354	50
FSV 335	45, 80, (90), (130), (140)	311	372	75	311	372	50
FSN 46		–	165	35	–	165	40
FSN 50		–	113	31	–	115	40
FSN 75		–	202	60	–	202	40
FSN 99		–	161	31	–	161	40
FSN 105		–	228	60	–	228	40
FSN 110		–	236	60	–	236	40
FSN 130		–	260	60	–	260	40
FSN 146		–	272	60	–	272	40
FSN 155		–	280	60	–	280	40
FSN 160		–	288	60	–	288	40
FSN 185		–	303	75	–	303	50
FSN 280		–	342	75	–	342	50
FSN 285		–	397	75	–	397	50

* Further expansion joint heights available on request

** Corner versions only available on request

WALL-CONNECTION VERSIONS

FS E4

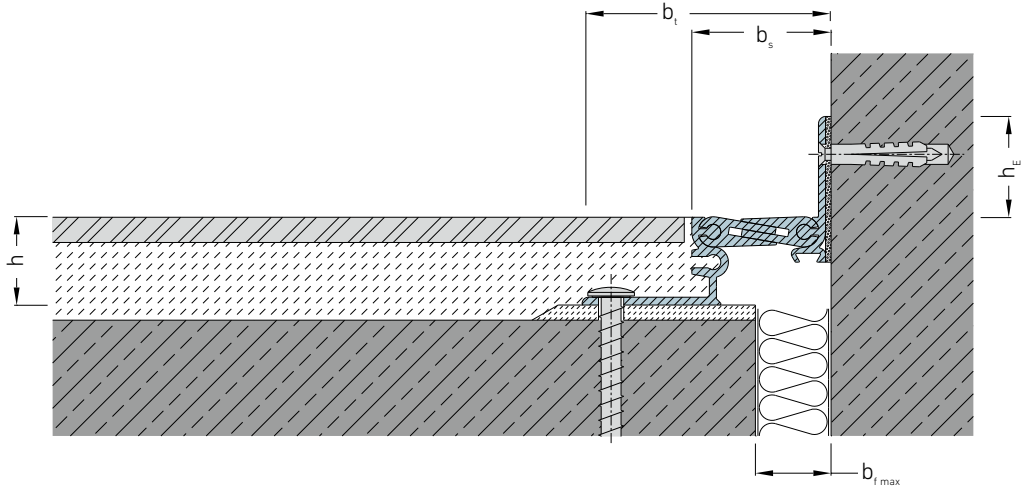

FS 50 E4

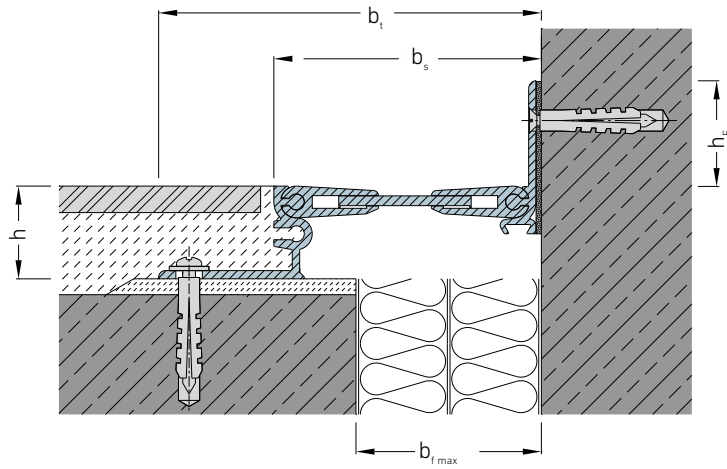

FS 99 E4

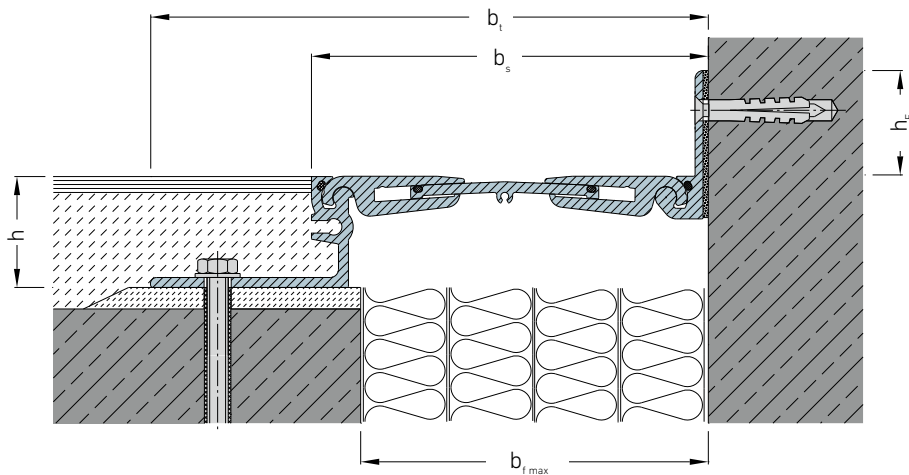

FS 146 E4

WALL-CONNECTION VERSIONS

FS E4

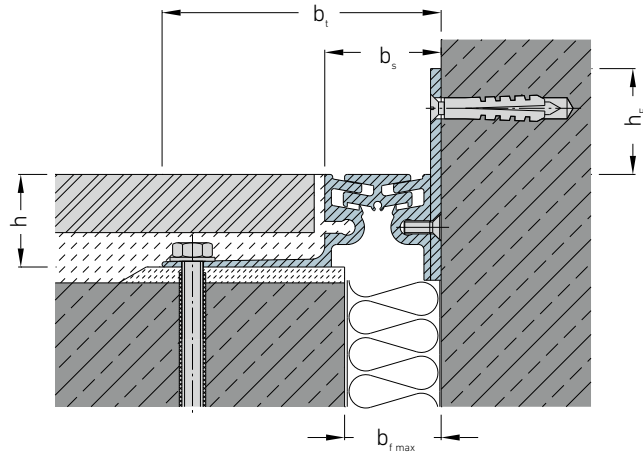

FS 40 E4

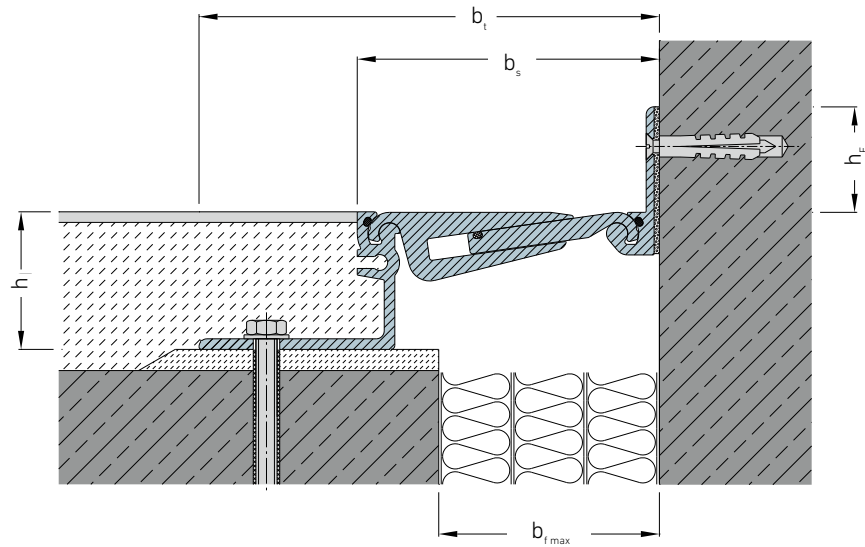

FS 75 E4
FS 110 E4
FS 130 E4
FS 160 E4

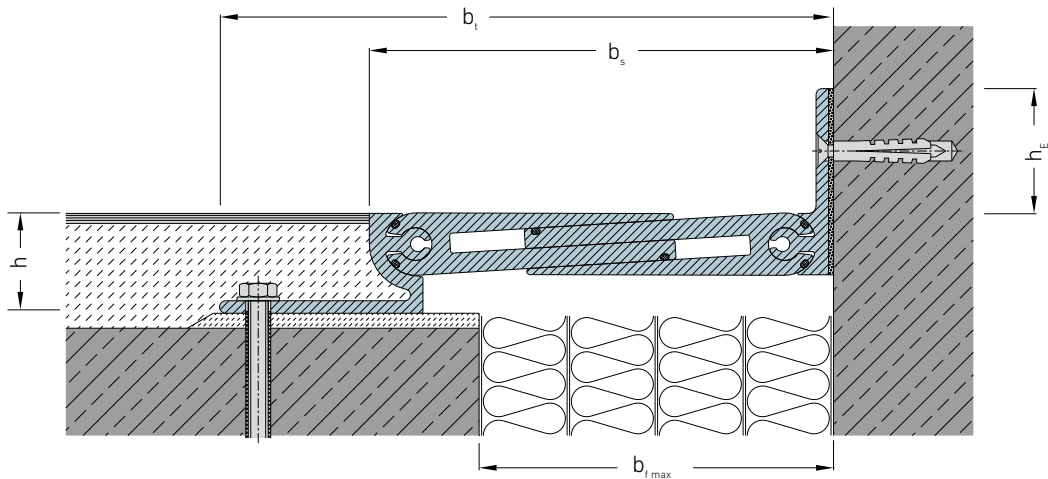

FS 185 E4

WALL-CONNECTION VERSIONS

FS / FSV E4

FS 105 E4
FS 155 E4

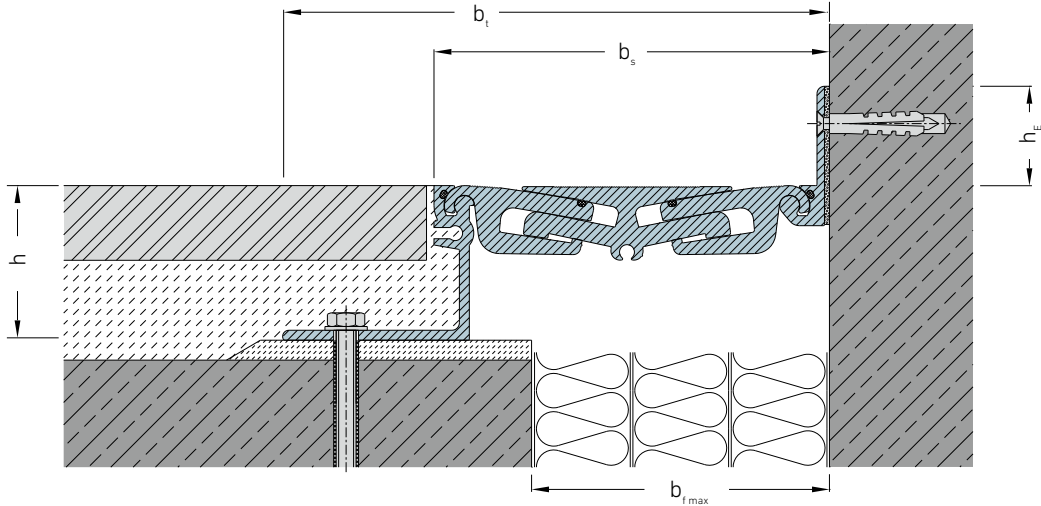

FSV 235 E4
FSV 280 E4

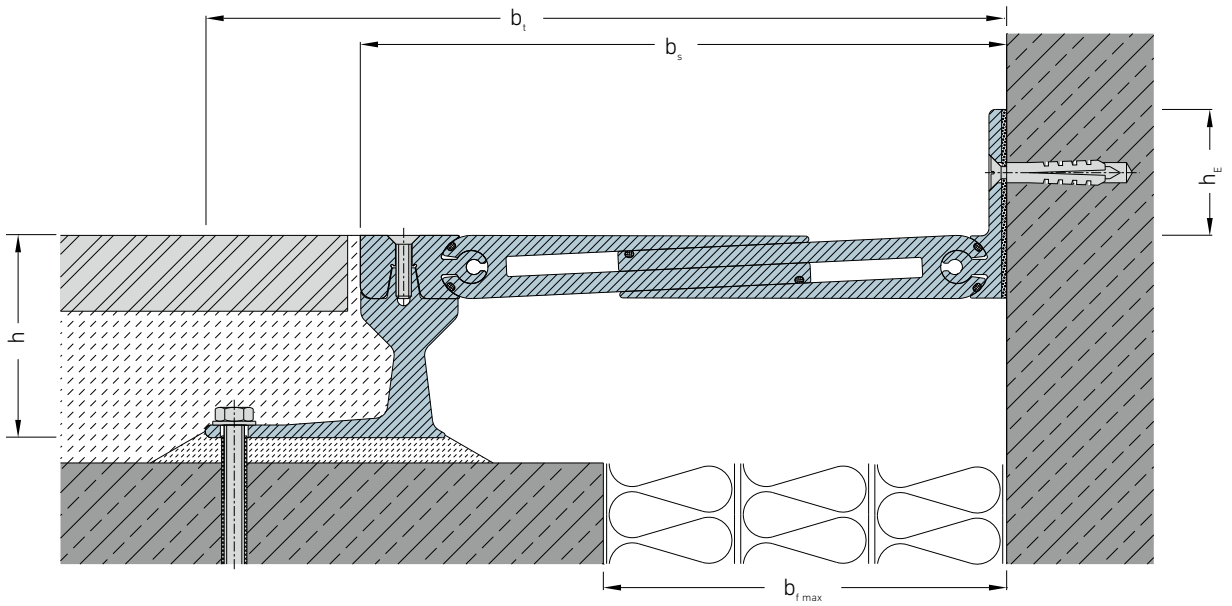

FSV 335 E4

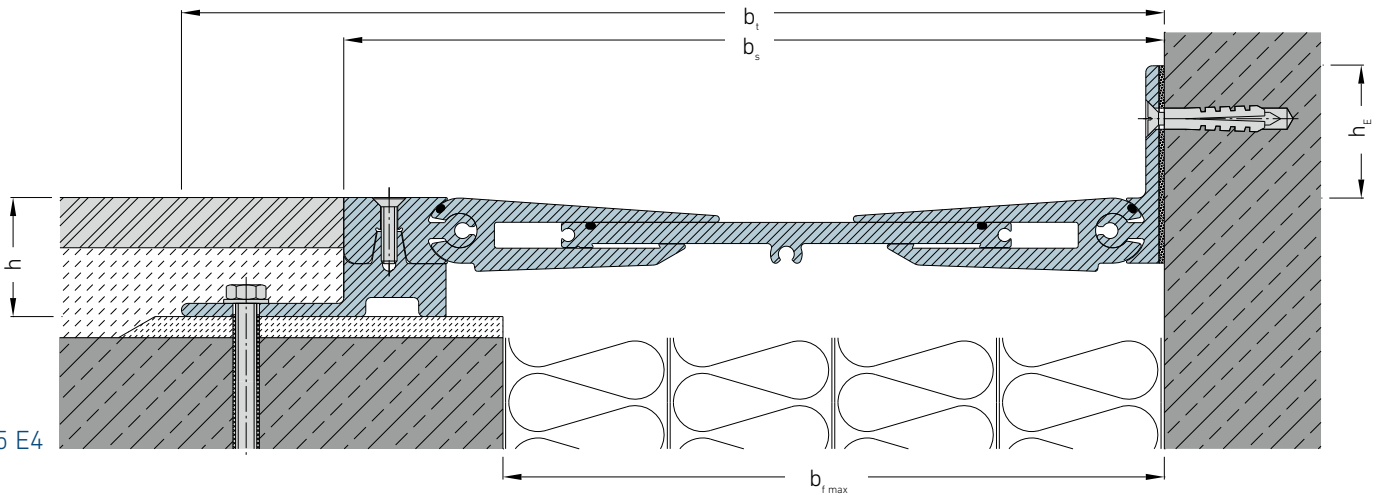

WALL-CONNECTION VERSIONS

FSV / FSN E4

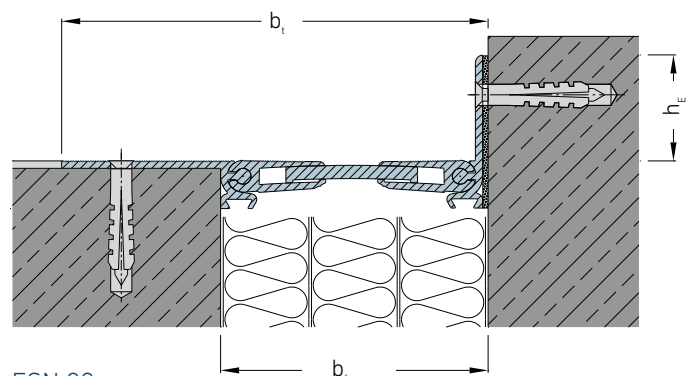
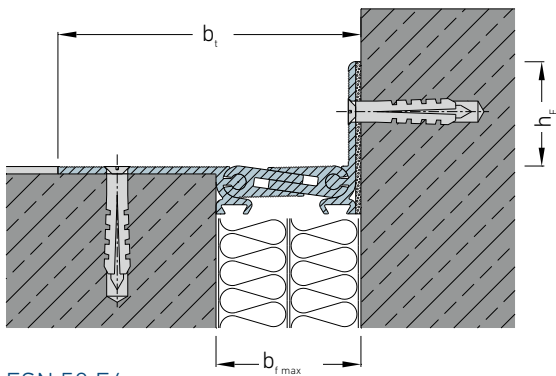
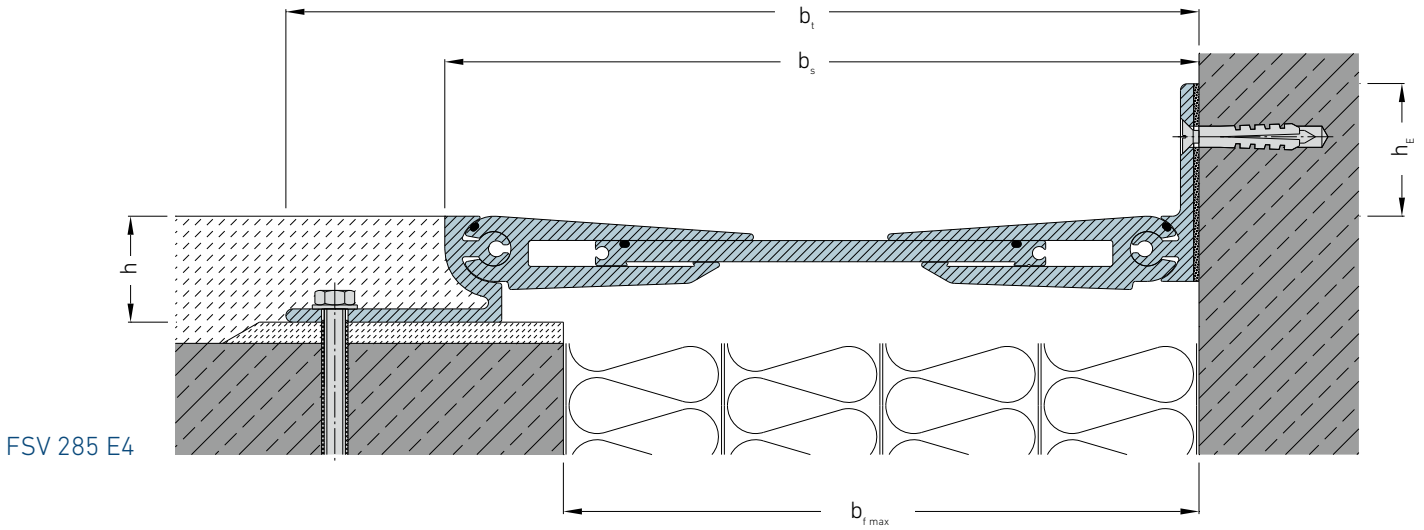

WALL-CONNECTION VERSIONS

FS E3

FSN 105 E4

FSN 155 E4

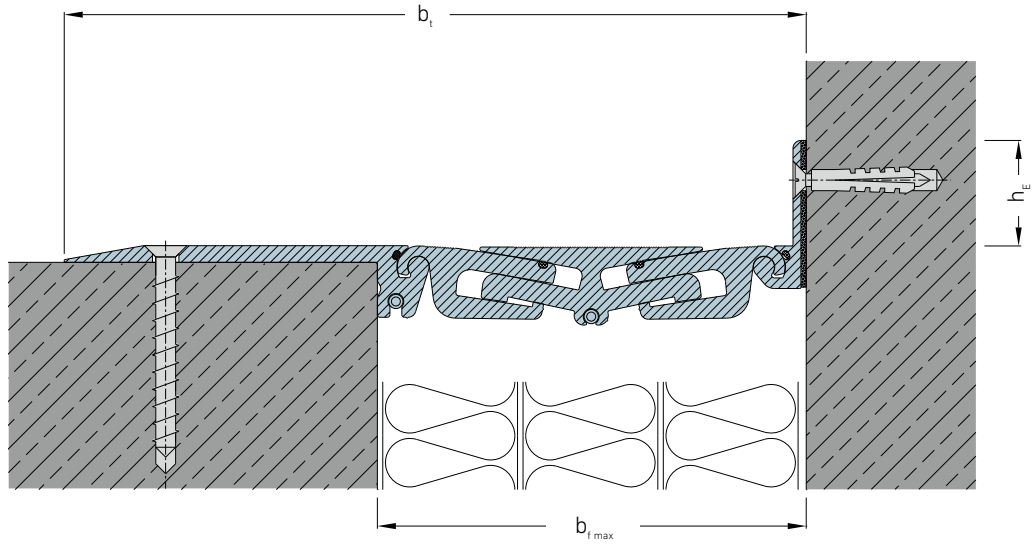

FS 50 E3

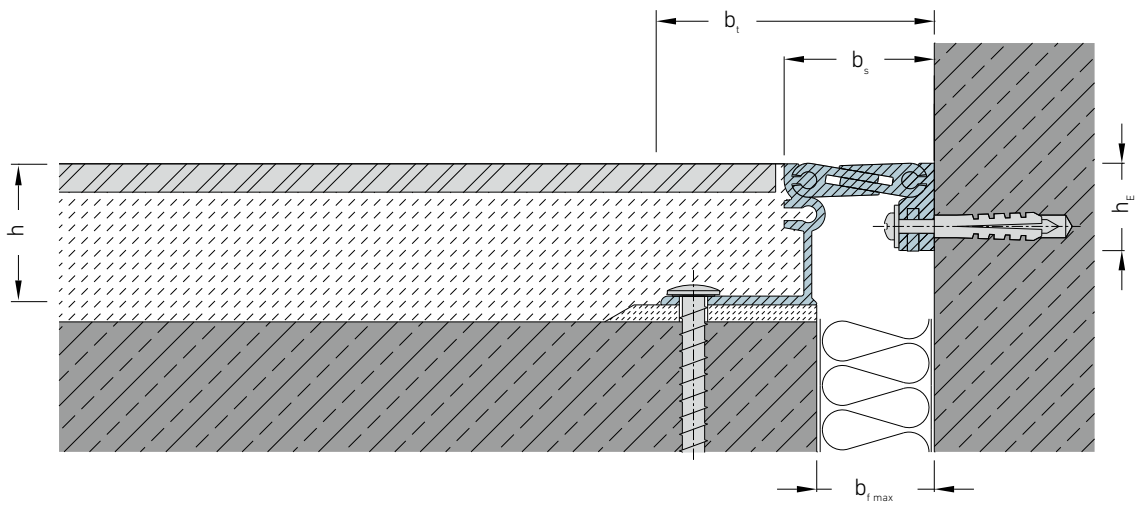

WALL-CONNECTION VERSIONS

FS E3

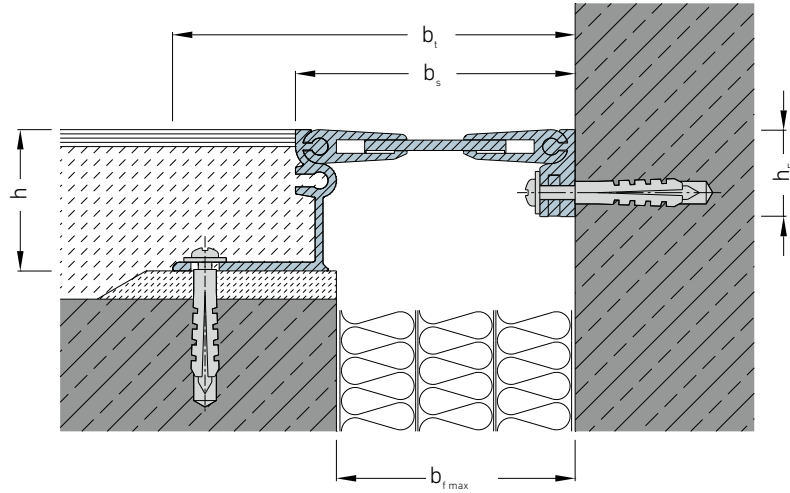

FS 99 E3

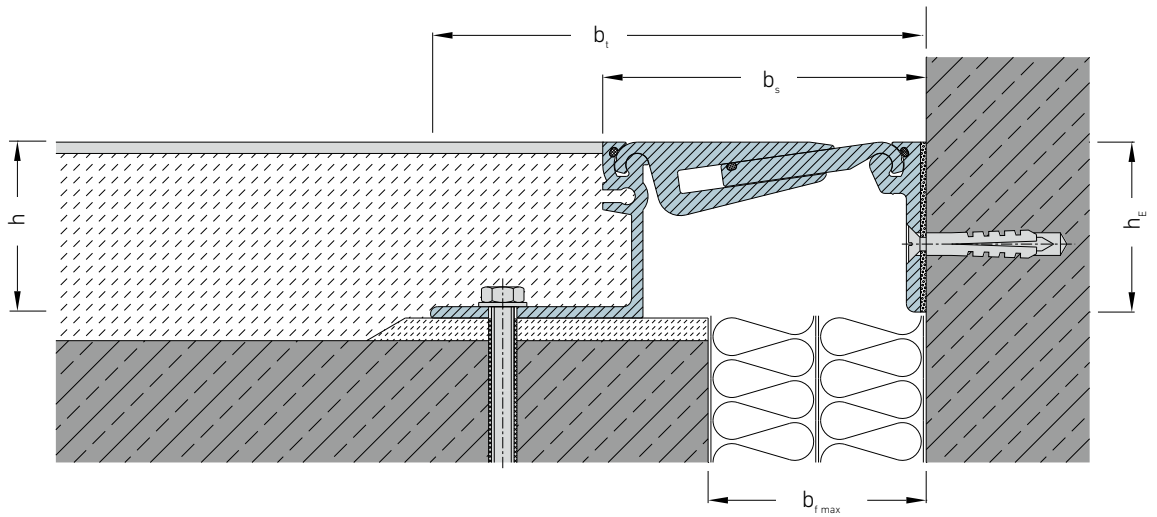

FS 75 E3
FS 110 E3
FS 130 E3
FS 160 E3

WALL-CONNECTION VERSIONS

FS E3

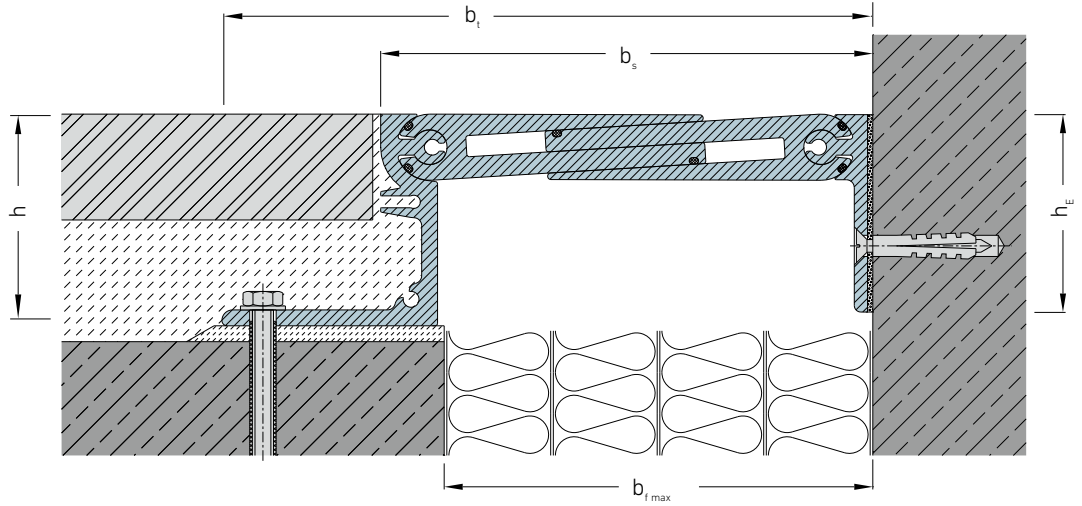

FS 185 E3

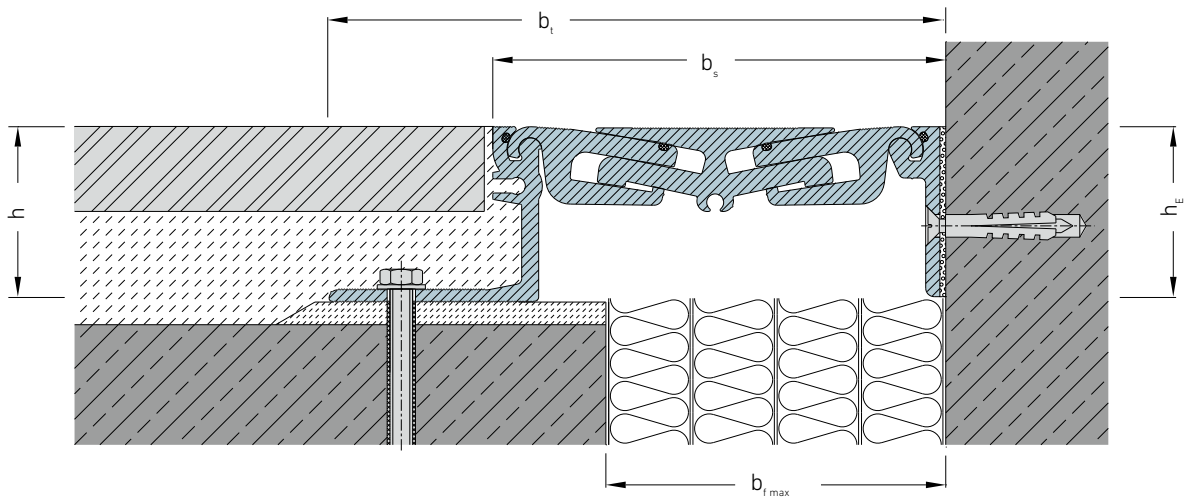

FS 155 E3

When using the E3 versions, please make use of our technical consultation services.

INSTALLATION SUGGESTIONS

EXPANSION JOINT COMBINATIONS

FS 75/22-62

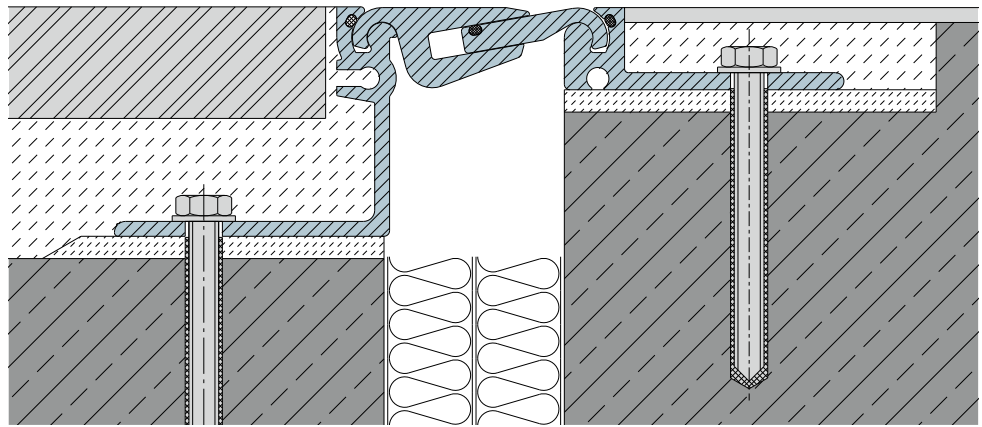

FS 75/62-150

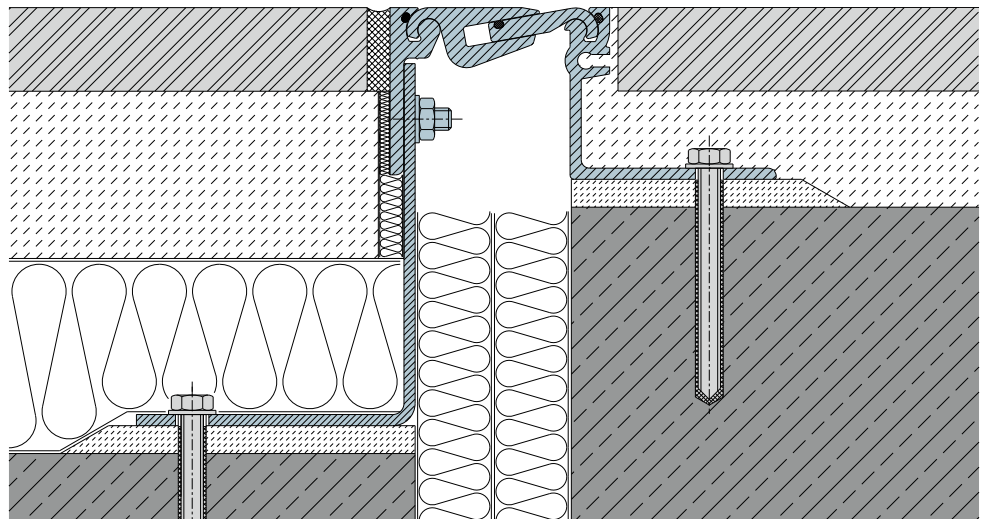

INSTALLATION SUGGESTIONS

IN SCREED

IN EXISTING CUT-OUTS

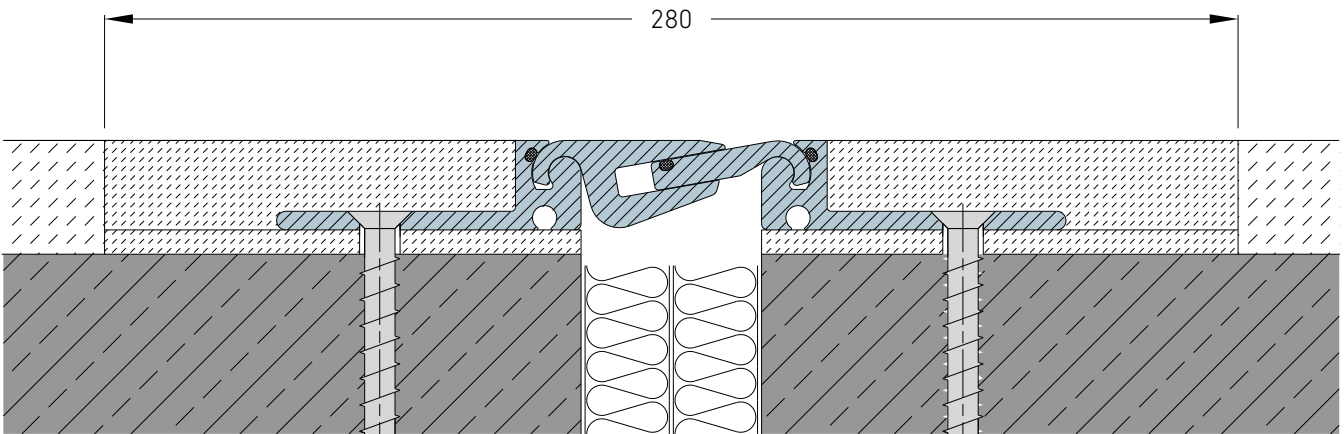

MIGUTRANS expansion joint construction, e.g. in conjunction with hard-aggregate floor screed, magnesite screed: FS 75/22

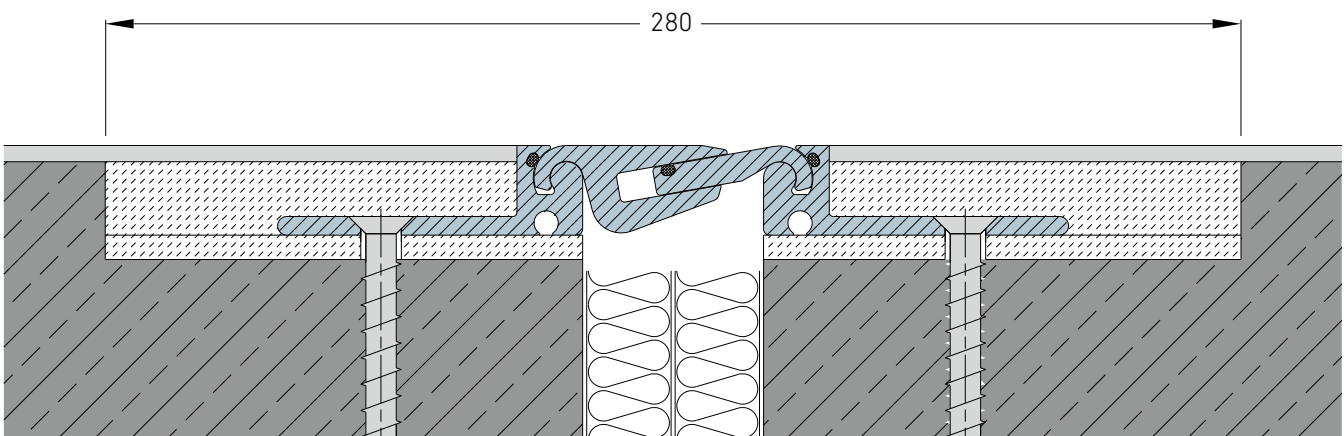

MIGUTRANS expansion joint construction in existing on-site cut-out with mounted expansion joint cover: FS 75/22

INSTALLATION SUGGESTIONS

LARGE CONSTRUCTION HEIGHT
EXTREMELY WIDE CONSTRUCTION JOINTS

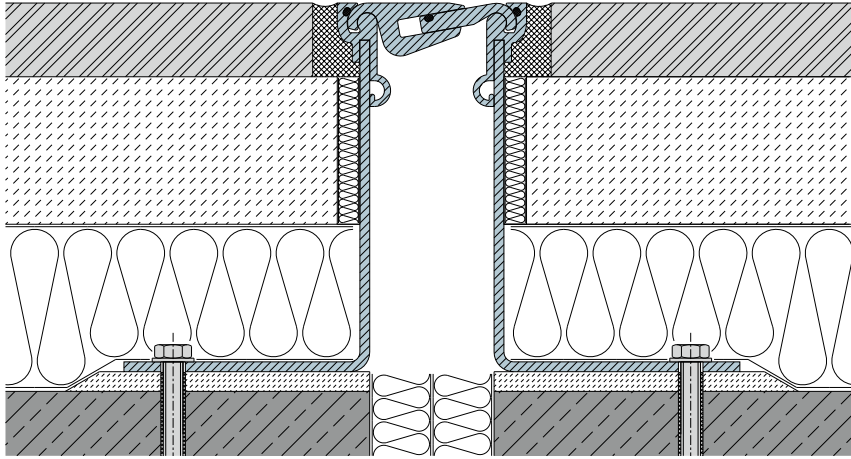

MIGUTRANS expansion joint construction for large construction heights

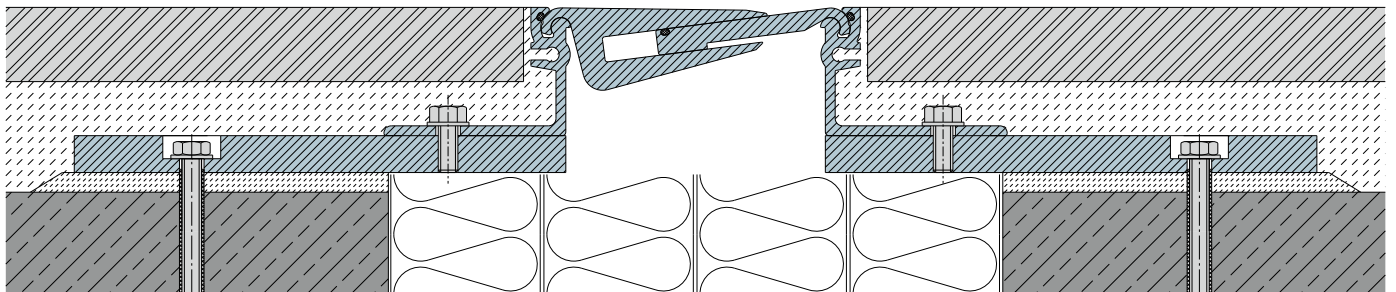

MIGUTRANS expansion joint construction with factory-supplied aluminium plates for extremely wide construction joints

INSTALLATION SUGGESTIONS WITH MIGUFOL TAPE

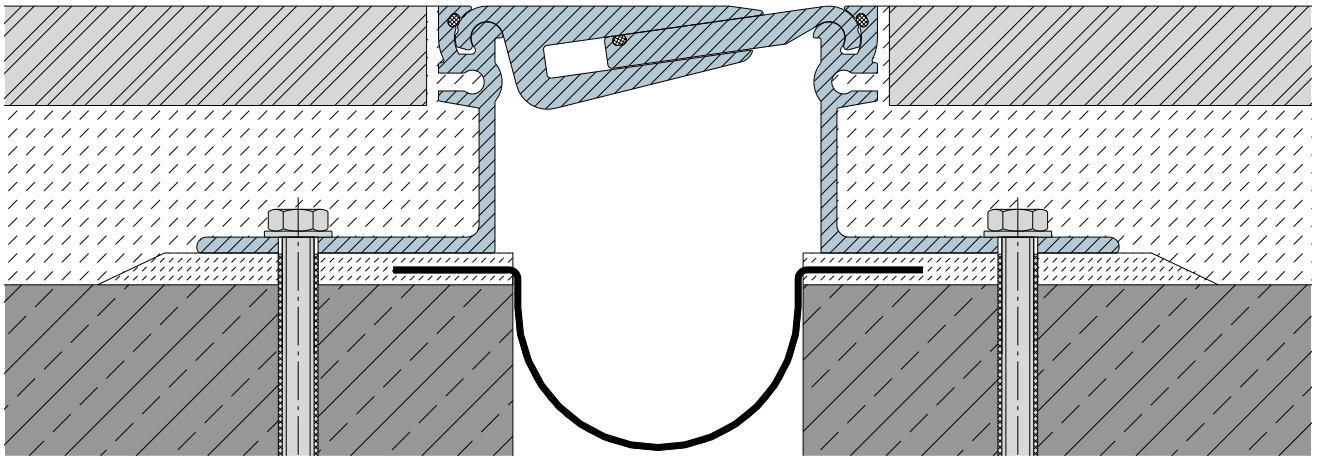

MIGUTRANS expansion joint construction with MIGUFOL tape

INSTALLATION SUGGESTIONS

CORNER SOLUTIONS

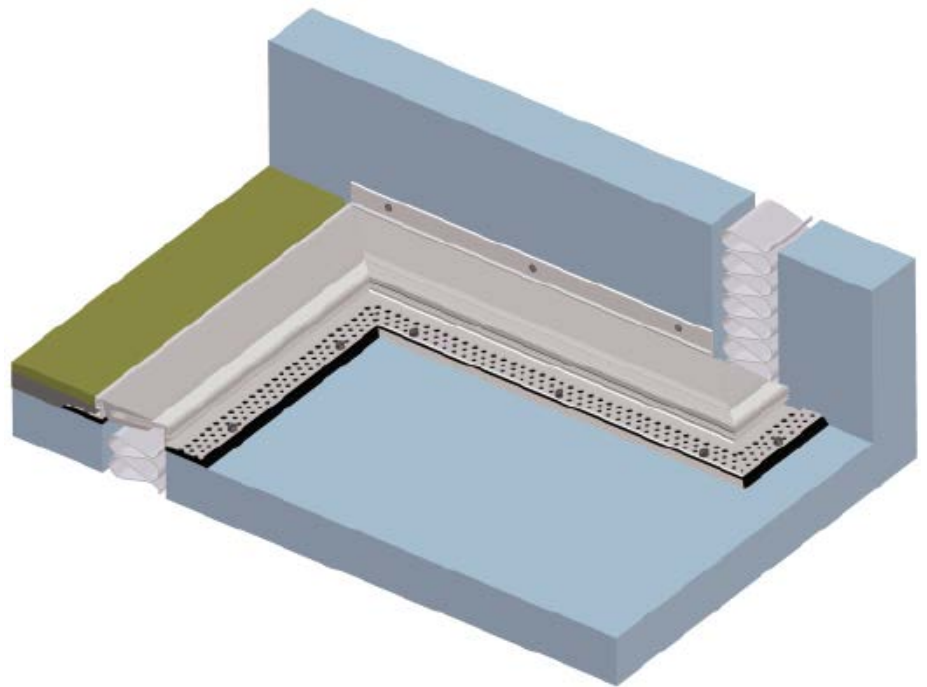
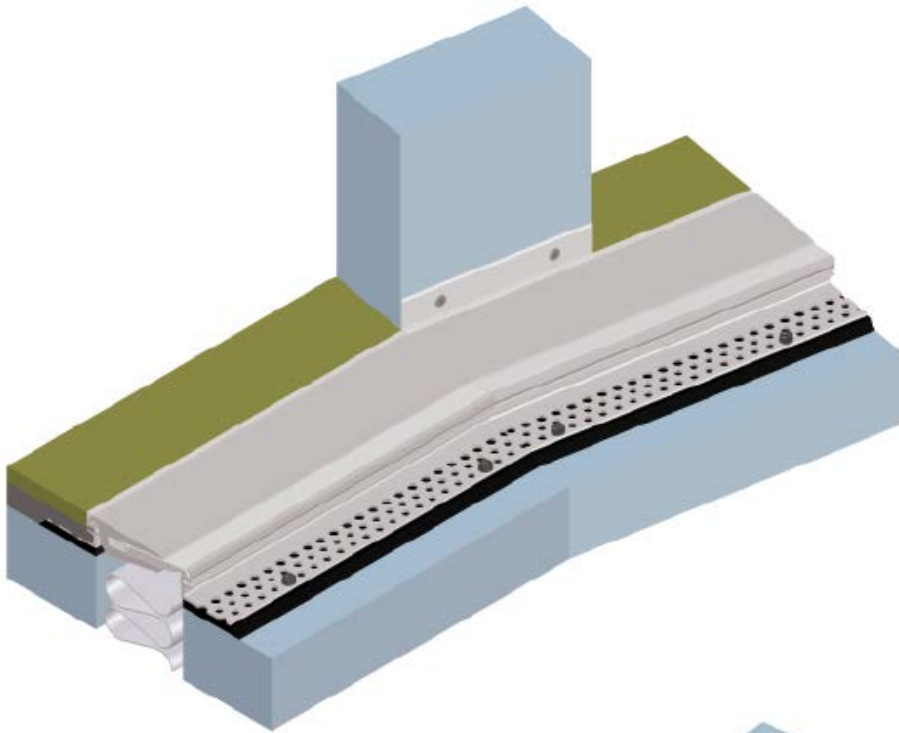

PRACTICAL APPLICATIONS MIGUTRANS

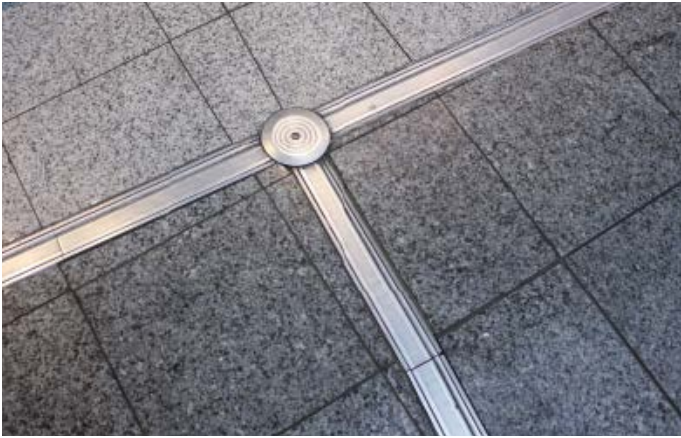

Goethe Galerie, Jena



Frankfurt airport



Uni-Klinik, Jena



Sachsen Allee shopping centre, Chemnitz



Hamburg airport, underground



Frankfurt main station



Hospital Berlin Marzahn

MIGUTRANS

HEAVY-DUTY ALL-METAL JOINT SOLUTIONS FOR LARGE TRAFFIC LOADS



Frankfurt airport



Trade fair, Leipzig



Millennium Bridge, London



City Centre Halle shopping centre



New market Bionorica



Festival hall, Frankfurt

LEGAL NOTES

All specifications in this catalogue, in particular the suggestions for processing and use of our products correspond to our current knowledge state. Despite the greatest possible care, we are not able to guarantee that the non-binding information is without errors.

Further, the installation details shown in this catalogue are theoretical in nature and do not represent real objects. We reserve the right to make technical changes.

The current version requested from us or downloaded from www.migua.com applies.

The texts and images are subject to copyright.

MIGUA Fugensysteme GmbH

Dieselstraße 20
42489 Wuelfrath, Germany

Fon +49 2058 774 0

Fax +49 2058 774 48

Mail info@migua.de

Web www.migua.com